

TUBE•LINE™

Tubeline Manufacturing Limited
6455 Reid Woods Drive RR #4
Elmira, Ontario, Canada N3B 2Z3

Email: sales@tubeline.ca

Fax: 519.669.5808

Tel: 519.669.9488

Toll-free (North America): 1.888.856.6613

www.tubeline.ca

Operator's Manual

Keep this manual with the machine at all times.

BF8000

Self Loading Balefeeder

BF8000SL

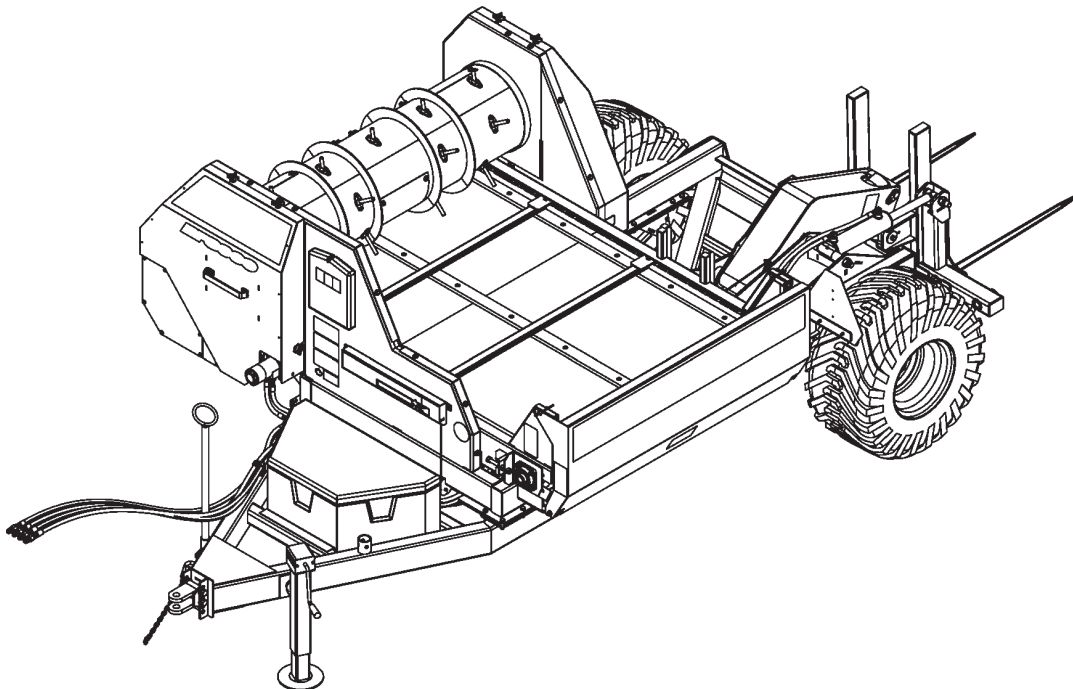

Operator's Manual

Thank you for choosing the Tubeline Self Loading Balefeeder.
We know it will give you many years of productive service.

Please read and understand this manual and the machine before operation.

Warranty and Limitation of Liability

All equipment is sold subject to mutual agreement that it is warranted by the company to be free from defects of materials and workmanship. But the company shall not be liable for special, indirect or consequential, damages of any kind under this contract or otherwise. The company's liability shall be limited exclusively to replacing or repairing without charge, at its factory or elsewhere, at its discretion.

Any material, or workmanship defects which become apparent within one year from the date on which the equipment was purchased, and the company shall have no liability for damages of any kind. The buyer by the acceptance of the equipment will assume all liability for any damages, which may result from the use or misuse by his employees or others.

Manuals

Manuals are printed and shipped with machines as they leave the manufacturer. Your machine may include parts or features not yet included in the initially shipped manual. The latest manual version can be found at www.tubeline.ca/support. Tubeline reserves the right to update and change manuals as seen fit. Dealers are informed of any pressing changes/ modifications. They can help you with any questions regarding replacement parts.

Serial Number

The implement serial number is located on the front left side of the frame. This number helps us to track changes and improvements and must be mentioned when ordering parts or requesting service. For your convenience, a space has been provided inside the front cover of this manual to record the serial number, model number, purchase date, and dealer name.

Model No: _____ BF8000SL _____

Serial No: _____

Date Purchased: _____

Dealer Name: _____

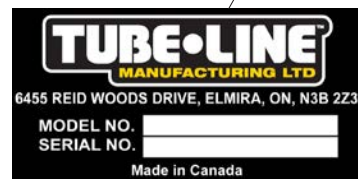
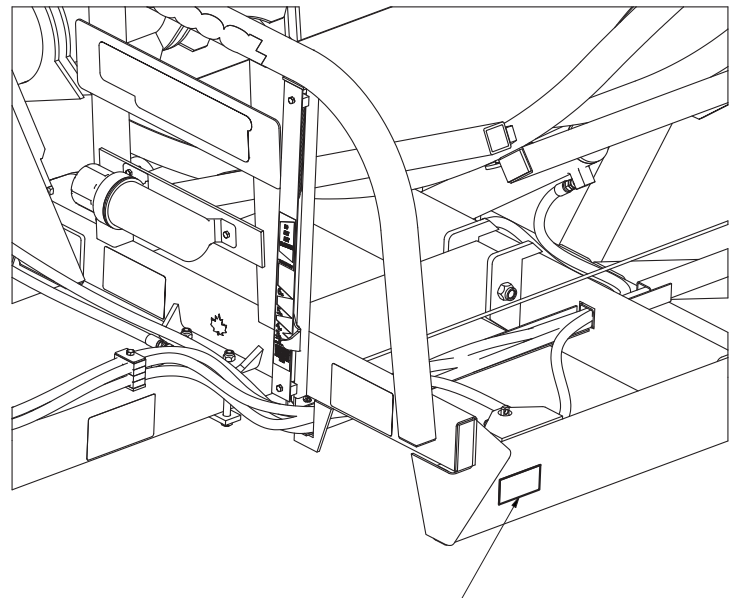

Table of Contents

Operator's Manual	I
Warranty and Limitation of Liability	I
Manuals	I
Serial Number	I
Section 1: General Information	1-1
Usage	1-1
Bales	1-1
Power Unit Requirements	1-1
Dimensions	1-1
Orientation	1-2
Terminology	1-2
Tire Load Index Chart	1-2
Section 2: Safety	2-1
Safety Signal Words / Safety Messages	2-1
Safety Guidelines	2-1
Personal Protective Equipment	2-2
Hydraulic Safety	2-2
Maintenance Safety	2-2
Decal Locations	2-3
Safety Decals	2-5
Safety Decals, continued	2-6
Model Decals	2-7
Section 3: Pre-Operation	3-1
Initial Setup	3-1
Bale Spear Installation	3-1
Power Unit Hookup	3-1
Section 4: Adjustments	4-1
Hitch Height	4-1
Bale Indicator	4-1
Conveyor Chain Tightening	4-2
Motor Drive Chain Tightening	4-2
Loading Arm Valve	4-2
Bed Stop Diverter Valve	4-3
Section 5: Operation	5-1
Loading Bales	5-1
Bed Stop	5-2
Unloading	5-3
Section 6: Maintenance	6-1
Grease Points	6-1
Grease Point Locations	6-2
Daily Maintenance	6-3
Preseason Service	6-3
End of Season Service	6-3

Section 8: Parts Breakdowns & Lists	7-1
Frame	7-2
Inner Shielding	7-4
Bale Bed	7-6
Bale Bed Conveyor	7-8
Drum - Original Welded End	7-10
45179 - Finger Drum Update Kit	7-12
Drum - Current	7-14
Front Chain Drive - Original	7-16
Front Chain Drive - Current	7-18
Rear Apron Chain - Original	7-20
Rear Apron Chain - Current	7-22
Loading Arm	7-24
Indicator	7-26
Bale Bed Cylinder Hydraulics	7-28
Conveyor Motor Hydraulics	7-29
Main Hydraulics	7-30
Loading Arm Hydraulics	7-32
Torque Values - Imperial	8-1
Torque Values - Metric	9-1

Section 1: General Information

Usage

This machine is designed to unravel round bales in a windrow for feeding livestock. The BF8000SL works well with hay, straw, baleage and silage. This machine does not alter material length.

Bales

The BF8000SL can handle up to a 5' x 6' diameter round bale. Maximum load capacity is 2500lbs.

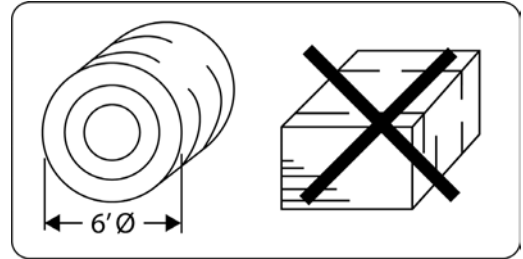

Power Unit Requirements

The BF8000SL requires a power unit with 8-16 GPM feed rate, a minimum of 2000PSI and a 40hp engine.

Dimensions

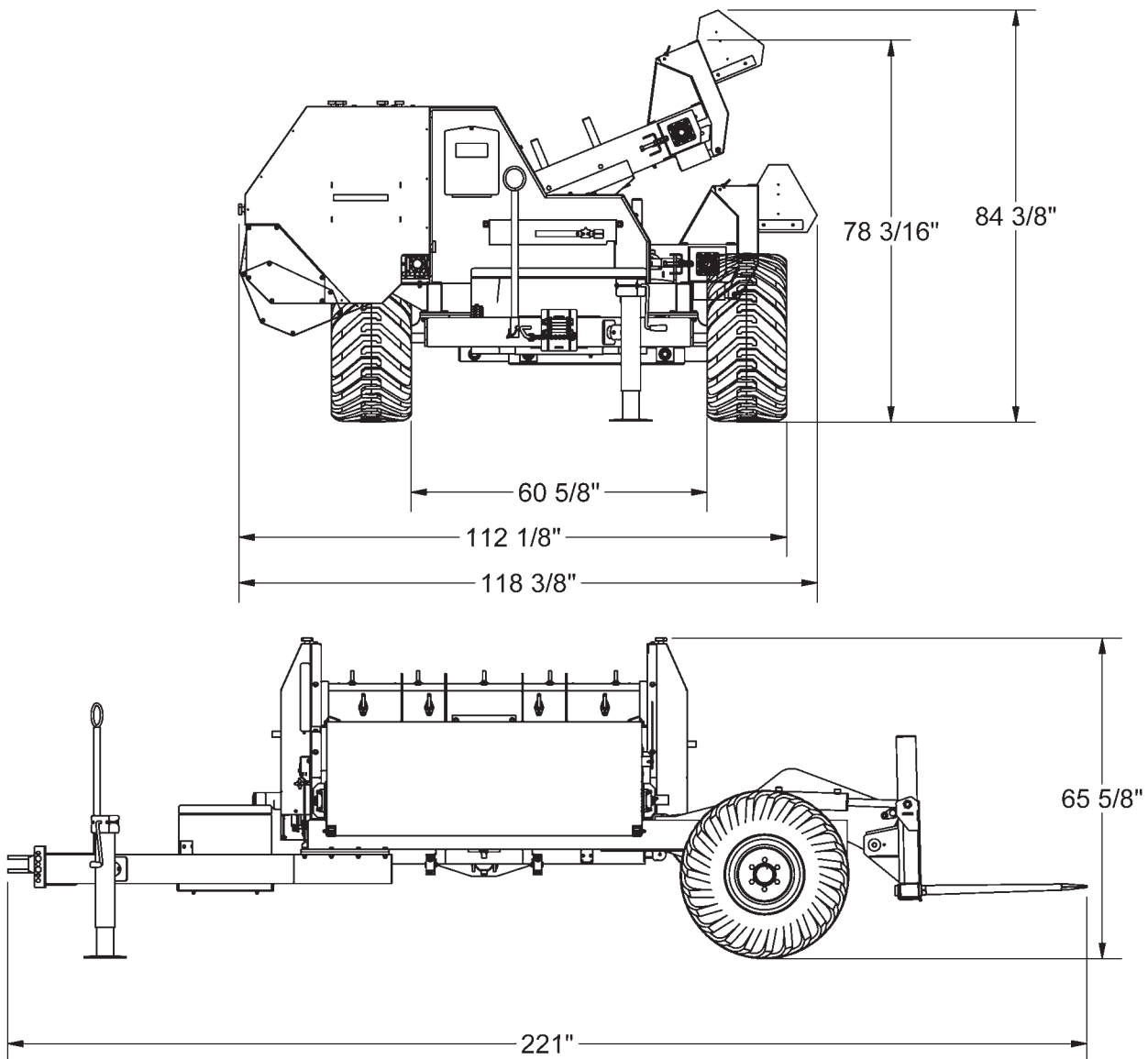

Orientation

Directional references in this manual are dependant on the operator's position from a forward pointed position while towing this machine.

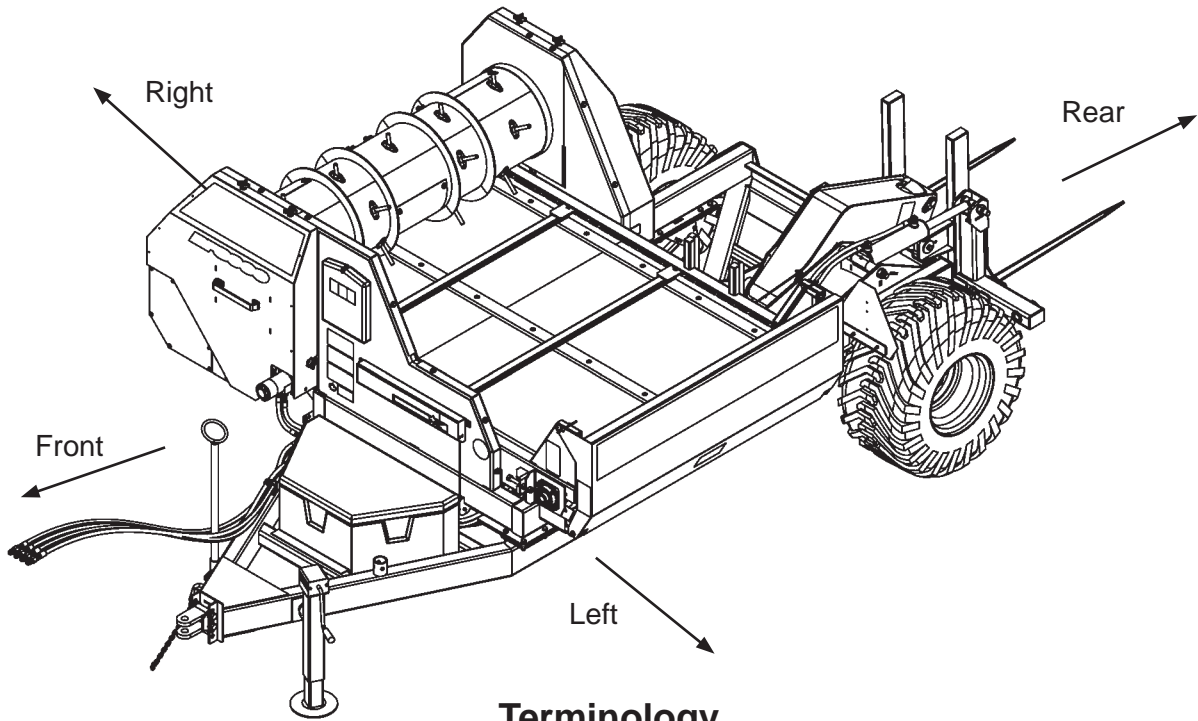

Terminology

Common terms used in this manual.

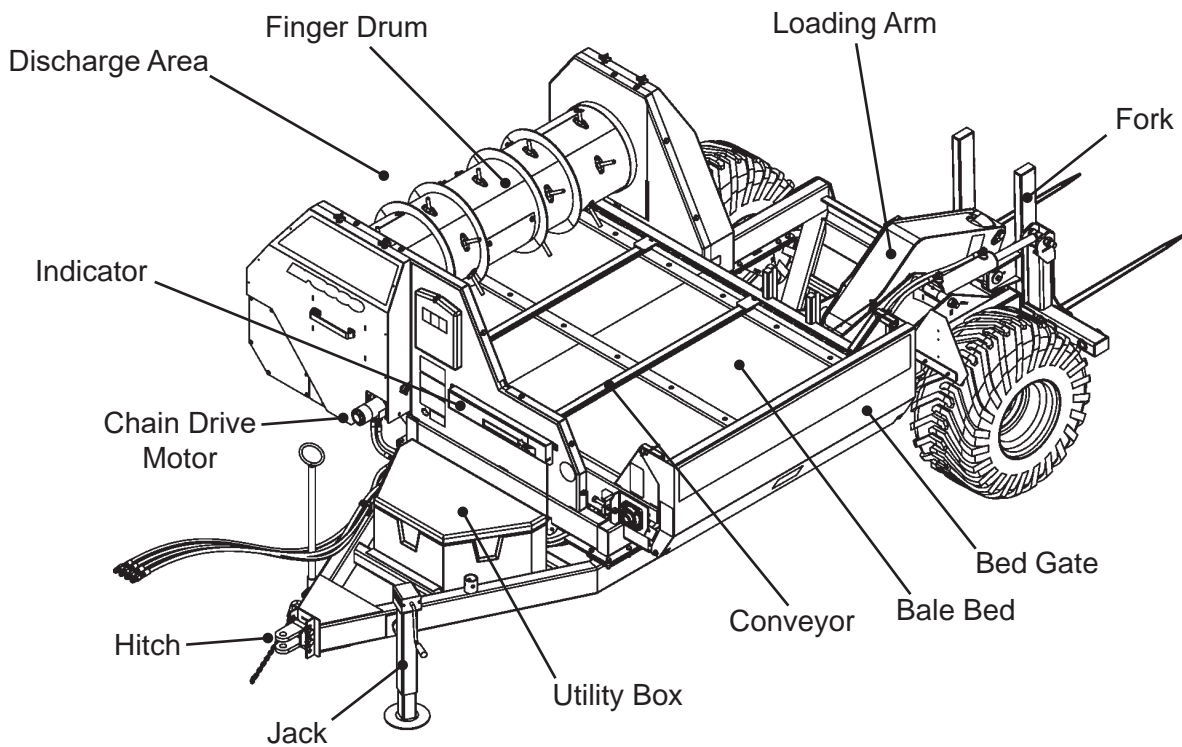

Tire Load Index Chart

400/60-15.5

Tire Size	Type	Rim	Unloaded		Static Load Radius	Rolling Circumference	Ply Rating	Load Index	Pressure	Load Capacity (lbs)			
			OD	SW						5 mph	15 mph	20 mph	25 mph
400/60-15.5	TL	AG 13	34.4"	15.7"	14.9"	102.6"	18	FR 149A8	65psi	10030	8530	8020	7160
								DW 137A8	65psi	7100	6030	5680	5070

Section 2: Safety

NOTE: This safety alert symbol is found throughout this manual to call attention to instructions involving yourself and others working around the machine.

Failure to follow these instructions can result in injury or death.



This symbol means:

- **Attention!**
- **Become Alert!**
- **Your Safety is involved!**

Safety Signal Words / Safety Messages

CAUTION: Indicates a potentially hazardous situation that may result in injury.

WARNING: Indicates a potentially hazardous situation that could result in serious injury or death.

DANGER: Indicates a hazardous situation that needs to be avoided. Operator needs to be aware of these dangers. High probability of serious injury or death.

NOTE: Indicates an informative non-safety related message.

Safety Guidelines

Take the necessary precautions to avoid injury or death. These include:

- Have training and train new operators.
- Review the safety instructions with all users annually.
- Know where safety decals are and what they convey.
- **DO NOT** paint over, remove or deface any safety signs or warning decals on your equipment.
- Replace damaged and/or missing safety decals.
- **DO NOT** operate without fully installed shields.
- Reinstall any removed shields **BEFORE** operating.
- Inspect machine before operating.
- **DO NOT** operate this machine while under the influence of drugs or alcohol.
- **DO NOT** let children ride or operate this machine.
- Keep a first aid kit and a fire extinguisher on site in case of emergency.

Personal Protective Equipment



WARNING: Wear work boots, gloves, and safety glasses when maintaining or repairing machine.

WARNING: Wear work boots and ear protection when operating machine.

DANGER: Do not wear loose clothing when operating or maintaining the BF8000SL.

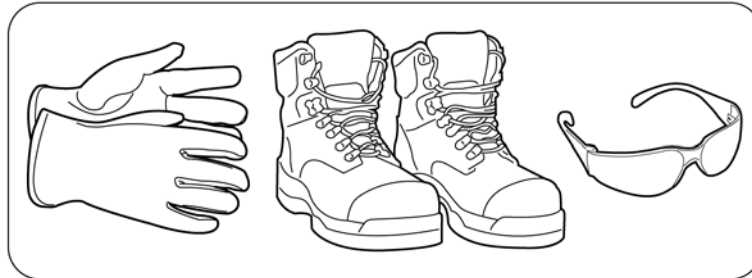

Hydraulic Safety

Before applying pressure to the system, be sure all connections are tight and that hoses and connections are not damaged.

Ensure that all the pressure is released from the hydraulic lines before repairing. Replace or repair damaged hoses immediately.



WARNING

When checking for oil leaks use a piece of cardboard; **DO NOT** use your hand:

- Escaping fluid under pressure can penetrate the skin causing serious injury.
- Avoid the hazard by relieving pressure before disconnecting hydraulic of other lines.
- Tighten all line connections before applying pressure.
- Protect hands and body from high-pressure fluids.

If an accident occurs, see a doctor immediately. Any fluid injected into the skin must be surgically removed within a few hours or gangrene may result. Failure to comply could result in serious injury, paralysis or even death.

Maintenance Safety

DO NOT weld on or near rotating parts. Welding close to rotating parts may cause warping thus creating high stress loads for moving or rotating parts.

DO NOT weld on wheel rims. Welding on wheel rims may cause high stress and wheel failure.

DO NOT weld on wheels with a mounted tire, Welding on wheels with a mounted tire may cause tire to burst, causing serious injury or death.

Decal Locations

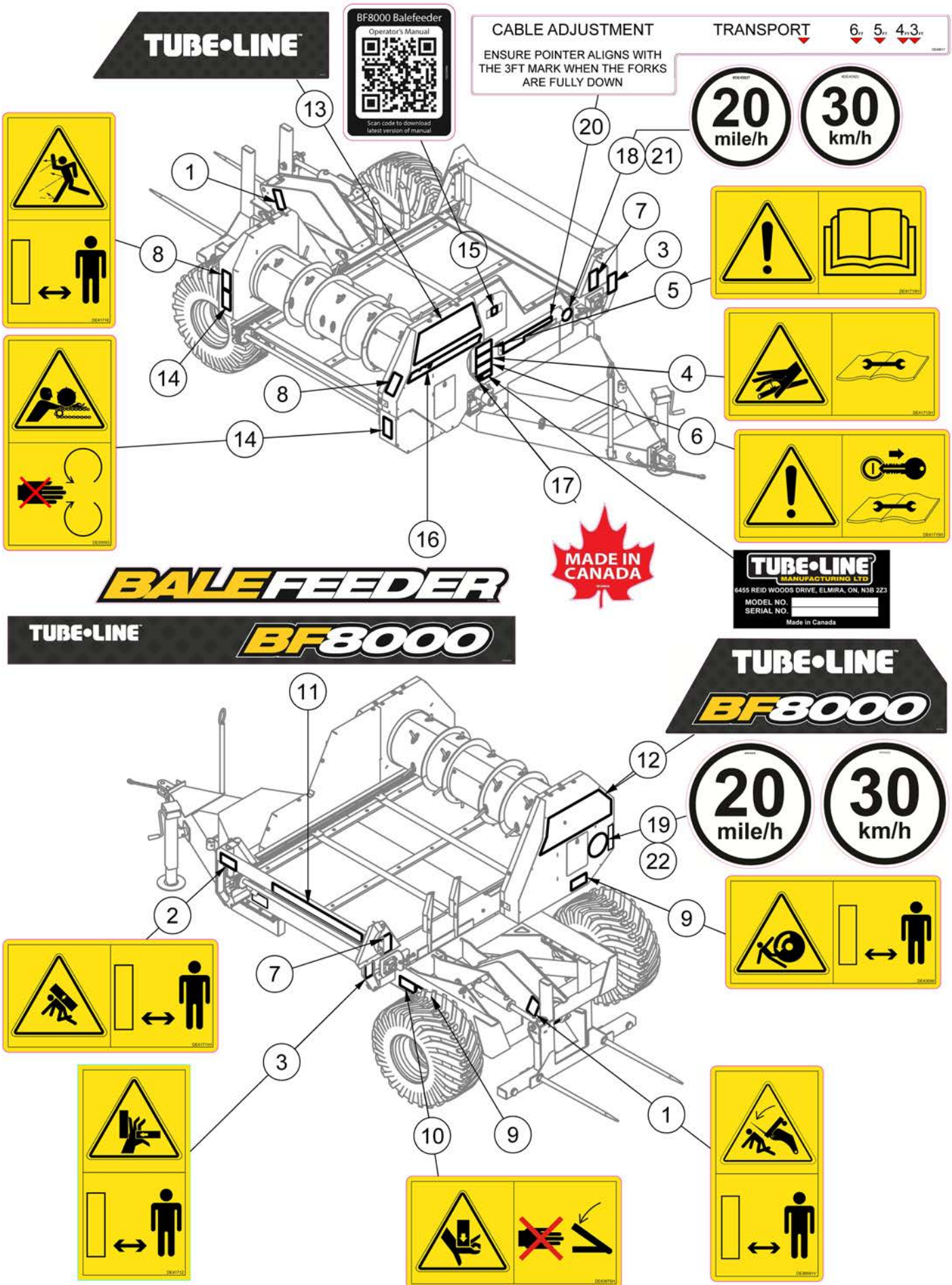

Decal Locations

ITEM	QTY	PART NUMBER	DESCRIPTION	NOTE
1	2	DE39591V	ISO Decal - Stay Clear of Forks Vertical	
2	1	DE41711H	ISO Decal - Angled Crush Horizontal	
3	2	DE41712	ISO Decal - Hand Pinch Point	
4	1	DE41713H	ISO Decal - High Pressure Fluid Horizontal	
5	1	DE41714H	ISO Decal - Read OM Horizontal	
6	1	DE41715H	ISO Decal - Remove Key Before Repair Horizontal	
7	2	DE41716	ISO Decal - Shaft Entanglement	
8	2	DE41718	ISO Decal - Thrown Object Vertical	
9	2	DE43049	ISO Decal - Wheel Crush	
10	2	DE43875H	ISO Decal - Hand Crush	
11	1	DE50061	BF8000 Balefeeder Decal	
12	1	DE50062	BF8000 Model Decal	
13	1	DE50063	BF8000 Tubeline Decal	
14	2	DE50093	ISO Decal - Chain Roller Entanglement	
15	1	DE50096	BF8000 QR Decal	
16	1	DE51355	Balefeeder Model Decal	
17	1	DECANADA	Decal Made In Canada	
18	1	DE45927	Decal - Small SIS 20mph	U.S. Only
19	1	DE45928	Decal - Large SIS 20mph	
20	1	DE49617	BF8000 Indicator Decal	
21	1	DE45925	Decal - Small SIS 30kmh	U.S. Only
22	1	DE45926	Decal - Large SIS 30kph	

Safety Decals



Item 1: DE39591V
Danger from free falling bale fork.

Stand clear of bale spear path to avoid injury or death.

Item 2: DE41711H

Crush hazard from lowering bed.

Stand clear of machine while operating and store bed in lowered position.



Item 3: DE41712

Hand pinch point hazard.

Keep fingers clear while closing gate.



Item 4: DE41713H

Hydraulic pressure puncture hazard.

Read manual maintenance section before repairing.



Item 5: DE41714H

Read Manual Before Operating Machine.



Item 6: DE41715H

Remove key from power unit and read manual maintenance section before attempting repairs.



Item 7: DE41716H

Shaft entanglement hazard.

Keep hands away from moving shaft and do not operate machine without shields in place.



Item 8: DE41718

Thrown object hazard.

Be sure all observers are clear of discharge area while operating.

Item 9: DE43049

Wheel crush hazard. Be sure all observers are clear machine while transporting/operating.



Item 10: DE43875H

Hand crush hazard. Keep clear from machine while lowering bale bed.



Safety Decals, continued



Item 16: DE50093

Entanglement hazard.
Keep hands clear of rotating drum and conveyor chain to avoid entanglement.



Item 19: DE45927

Small Speed Indicator sign for U.S. machines.



Item 20: DE45928

Large Speed Indicator sign for U.S. machines.

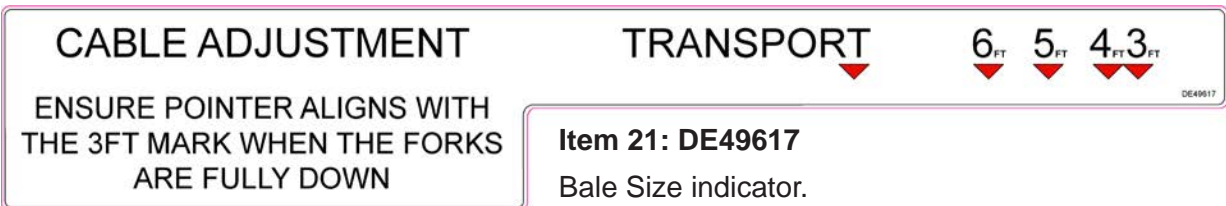

Item 21: DE49617

Bale Size indicator.



Item 26: DE45925

Small Speed Indicator sign for international machines.



Item 27: DE45926

Large Speed Indicator sign for international machines.

Model Decals

Item 12: DE50061

Large Balefeeder model decal.



Item 13: DE50062

BF8000 model number / Tubeline decal.



Item 14: DE50063

Tubeline Mfg Ltd decal.



Item 15: DE50064

BF8000 model number decal.



Item 17: DE50096

Scan QR code with smartphone camera to open website with this manual's download link.

Item 18: DECANADA

This product is proudly manufactured in Canada.



Section 3: Pre-Operation

Initial Setup

Your BF8000SL may need some pre-assembly prior to first use. In some circumstances the tongue and bale spears may be removed for shipping and need be installed. Optional features may also be shipped separately and need to be installed. All needed fasteners are provided by manufacturer.

Bale Spear Installation

The bale spears must be attached to the bale fork to the rear of the machine.

NOTE: Supplied conus nuts are the only supported fasteners to secure bale spears.

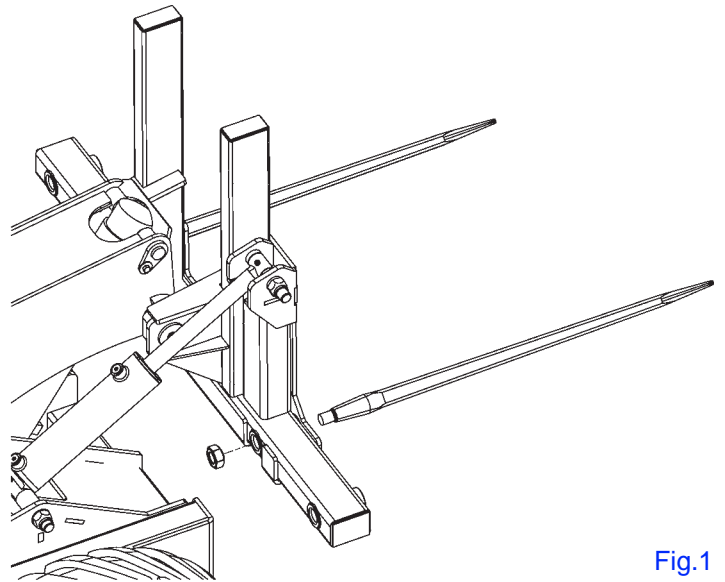

Fig.1

Power Unit Hookup

- Connect hitch (A) to power unit drawbar with pin.
- Connect 4 hydraulic quick couplers (B) to power unit hydraulic outlets.
- Make sure parking brake is released before driving away.
- Raise jack (C) when transporting.

When not in use, hydraulic hoses can be securely stored by looping them through hose support (D).

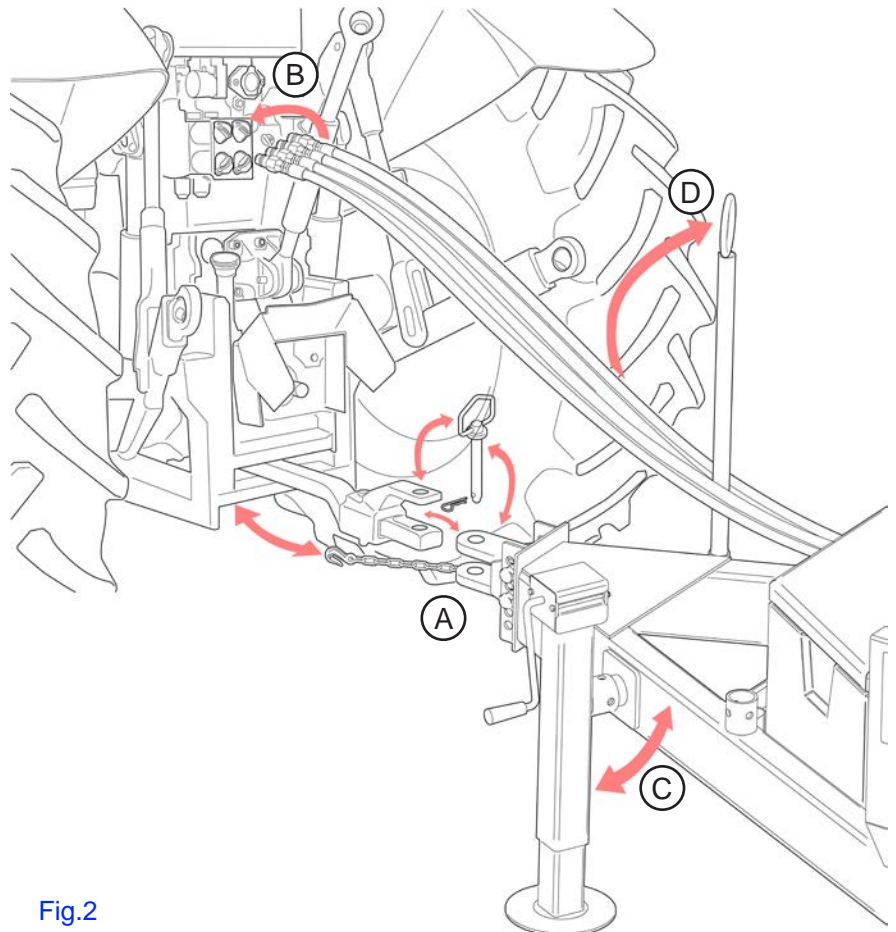

Fig.2

Section 4: Adjustments

Hitch Height

1. Ensure jack is lowered and set to a height that aligns bale bed parallel to ground.
2. Loosen and remove hitch bolts and nuts.
3. Raise or lower hitch to fit your power unit's drawbar.
4. Align hitch holes with frame holes.
5. Reinstall and fasten nuts and bolts.

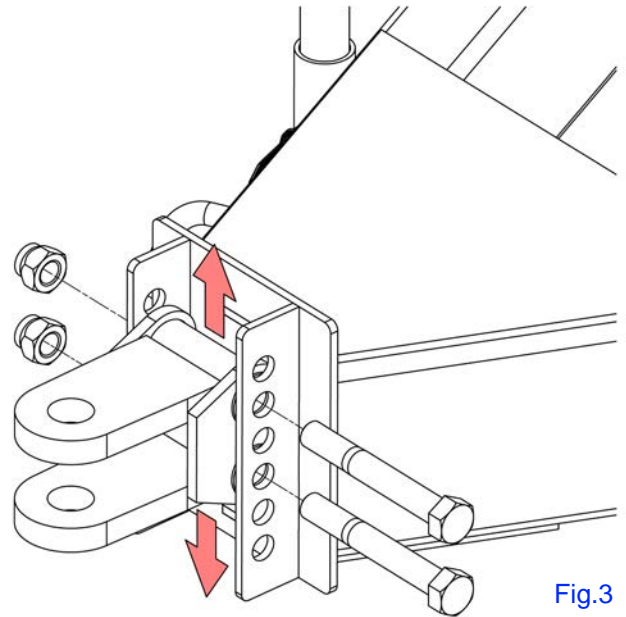

Fig.3

Bale Indicator

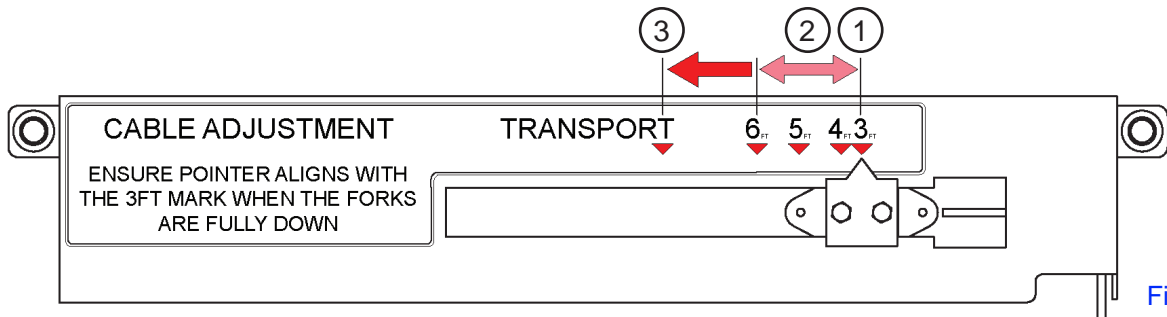

Fig.4

The bale indicator located on the front left of the machine is attached to the loading arm via pulleys and a cable, see [pg.8-18](#).

The bale indicator allows you to pierce bales at the right height for different bale sizes.

It may need to be adjusted as the cable stretches over time to remain accurate.

1. The bale indicator should be set so that when arrow aligns with the **3ft** mark when the bale fork is fully lowered. This is the position for loading 3' bales.
2. When the bale fork is raised to a height that the indicator arrow aligns with 4ft, 5ft, or 6ft, that is the loading position for that bale size.
3. Raise the bale fork so the indicator arrow aligns with **TRANSPORT** mark before moving machine with bale on fork.



WARNING: Lifting the bed while the indicator is in this area may cause the bale to twist the bale fork.

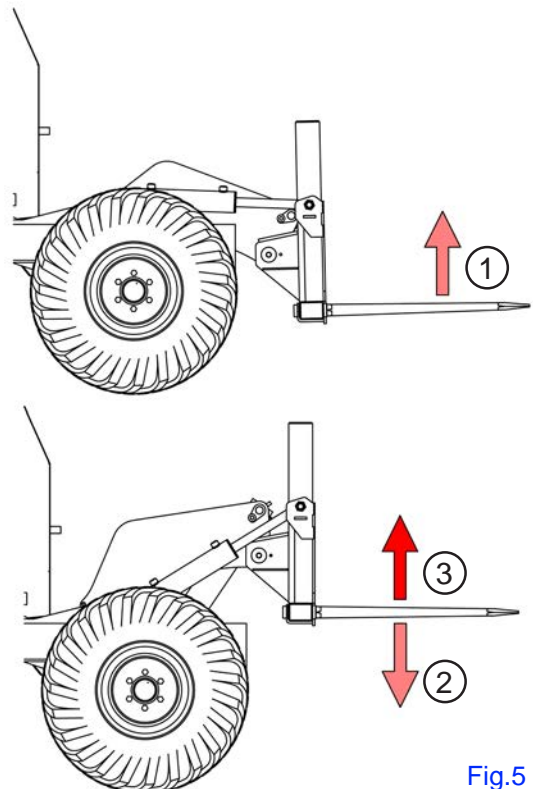
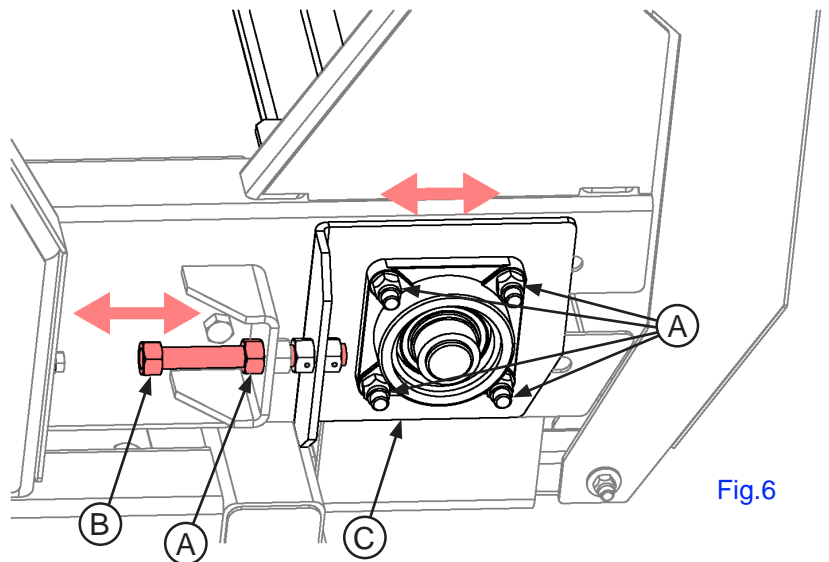

Fig.5

Conveyor Chain Tightening

Over time the bale bed conveyor chain may loosen. To tighten the chain:

1. Loosen nuts **(A)** on both sides of machine.
2. Turn in threaded bolt **(B)** to move the bearing plate **(C)** towards the bed gate. Make sure to move both sides the same amount.
3. Tighten Step 1 nuts to lock new position.



Motor Drive Chain Tightening

Over time the finger drum and conveyor's motor drive chain may loosen. To tighten the chain:

1. Loosen nut **(A)** on both sides of machine.
2. Use hex drive key to loosen 4 set screws **(B)** to allow bearing plate **(C)** to move.
3. Turn in threaded bolt **(D)** to move the bearing plate and tighten chain **(E)**.
4. Tighten Step 1 nuts and Step 2 set screws to lock new position.

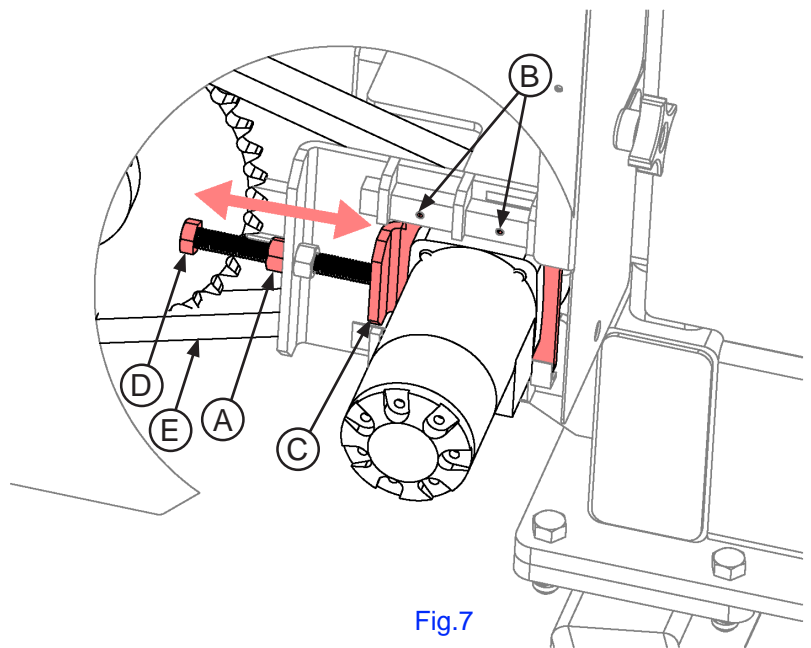

Loading Arm Valve

The rear sequencing valve highlighted in [Fig.8](#) controls how the load arm cylinders operate together. As the large cylinder raises the load arm, the smaller cylinder extends to keep the fork at an angle that will keep the bale seated securely on it.

If this needs to be reset:

1. Loosen the outer hex nut **(A)**.
2. Turn hex head set screw **(B)** completely clockwise, then counterclockwise 5 rotations.
3. Tighten hex nut to lock position.

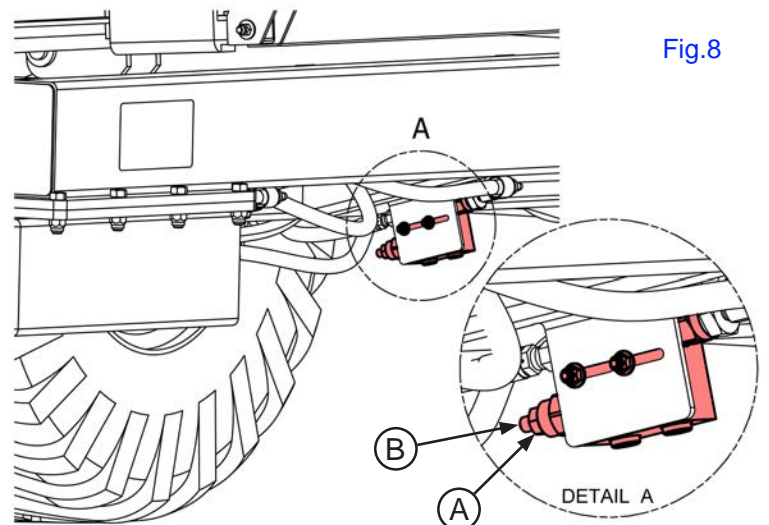

Bed Stop Diverter Valve

To operate correctly the bed stop diverter valve plunger **(A)** should be set $7/16''$ (11mm) above top of the plate the plunger protrudes through **(B)**.

Fig.9

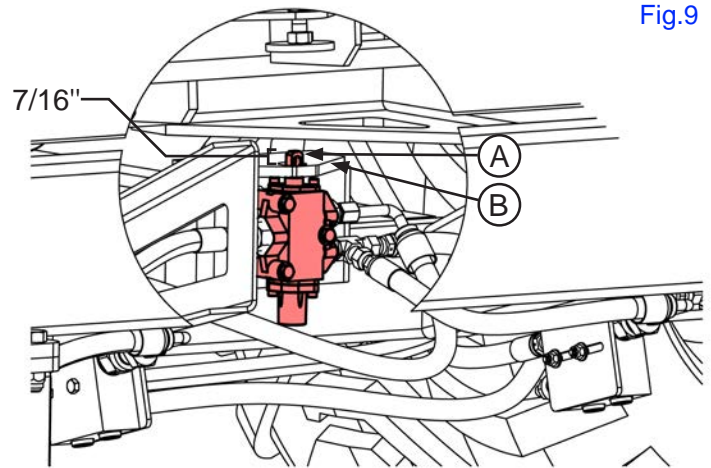

Section 5: Operation

Loading Bales

1. Set tractor hydraulic pressure to 12 gpm. This can be increased if operating speed is too slow. Use indicator to set bale fork height to match your bale size. As a visual cue, top of bale fork should be aligned with top of bale. Reverse the unit, keeping the forks centered on the bale, and pierce bale.

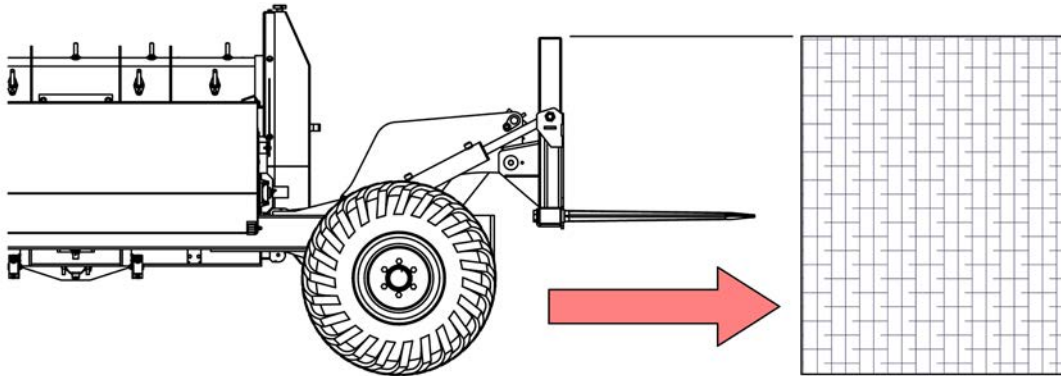

Fig.1 - Side View

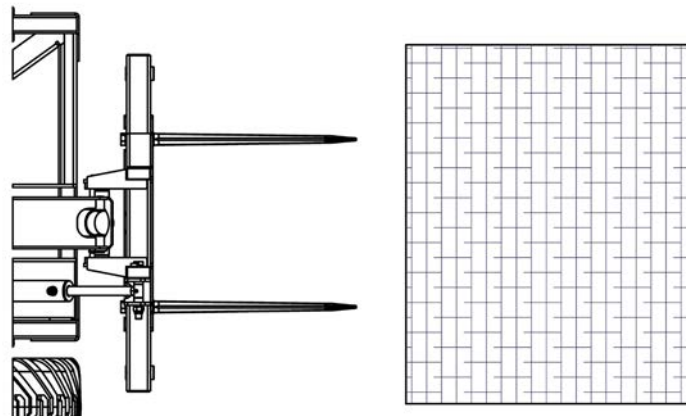

Fig.2 - Top View

2. Apply hydraulic pressure to loading arm circuit, lifting the bale onto the bed.
3. If bale has plastic or net wrap covering it can be easily removed once the bale is off the ground. The covering material can be placed in the front storage bin [Fig.4 \(1\)](#) until it can be properly disposed of.
4. After bale is on bed, retract the loading arm cylinder which will lower the bale fork into loading position for the next bale.

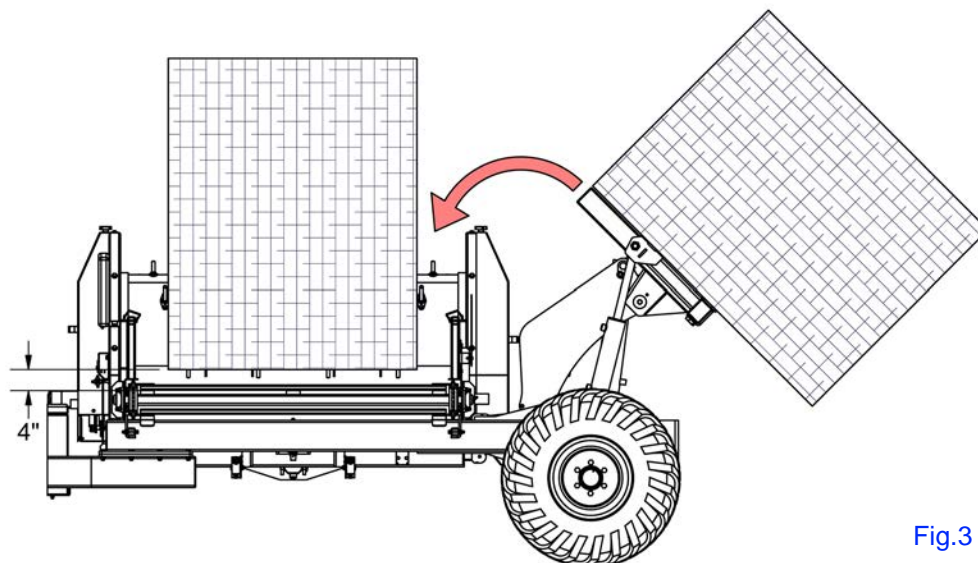

Fig.3



WARNING: Do not raise bed while loading arm is raised. Doing so can damage the bed or the loading arm.

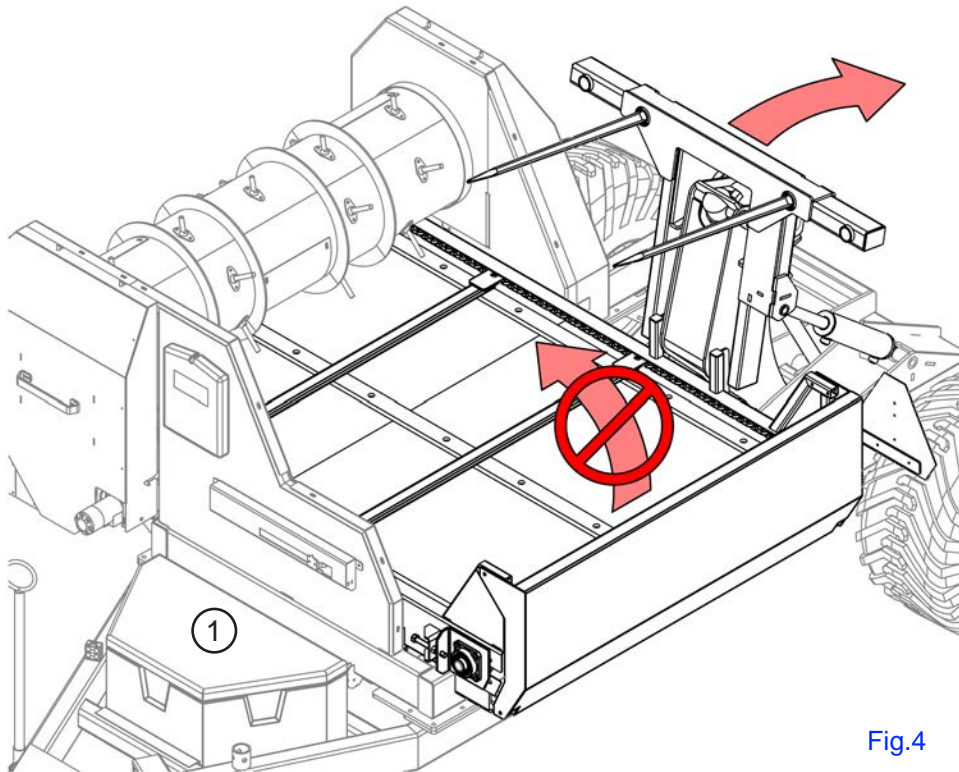

Fig.4

Bed Stop

When the bale has been placed on the machine the bed (1) can be raised slightly. This causes the bed stop (2) to disengage the diverter valve (3), stopping hydraulic pressure to the loading arm. This keeps the arm from being raised and damaging itself or the bed.

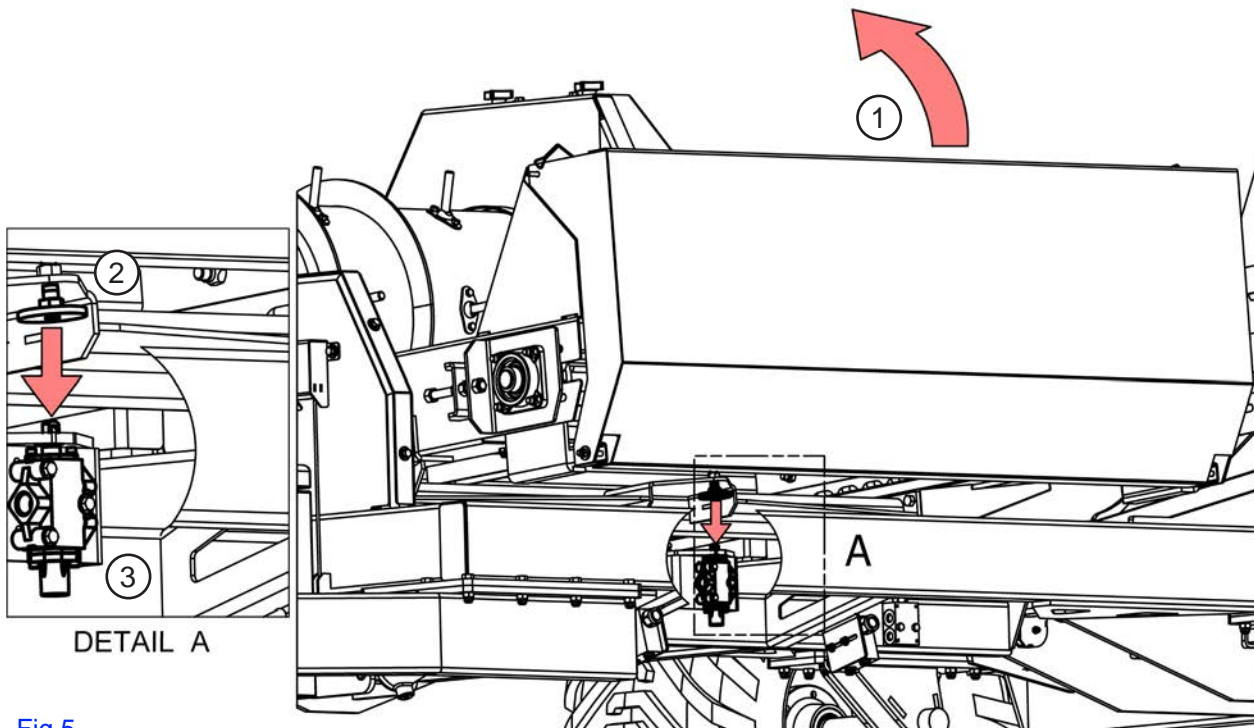

Fig.5

Unloading

To unravel the bale, use the power unit's hydraulic controls to engage the bale conveyor and finger drum motor. The bale will feed best when it is allowed the time to unravel and flow over the finger drum. Drive tractor or power unit forward to create a windrow, adjusting the speed to increase or decrease to desired size.

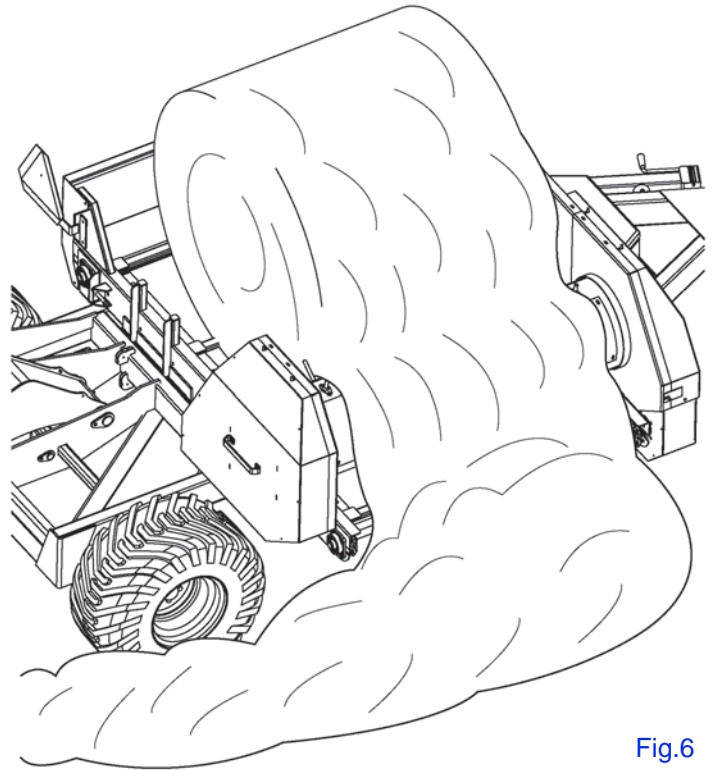

Fig.6

As the bale unravels, raise the bed in small increments to keep the bale engaged with the finger drum. A second bale can be loaded onto the bed when the currently loaded bale core becomes small enough to allow it.

NOTE: If the bale becomes misaligned and refuses to unroll, lower bed to disengage bale from finger drum and raise the bed at a slower pace. The conveyor chain can also be moved forward and reversed to remove blockage.

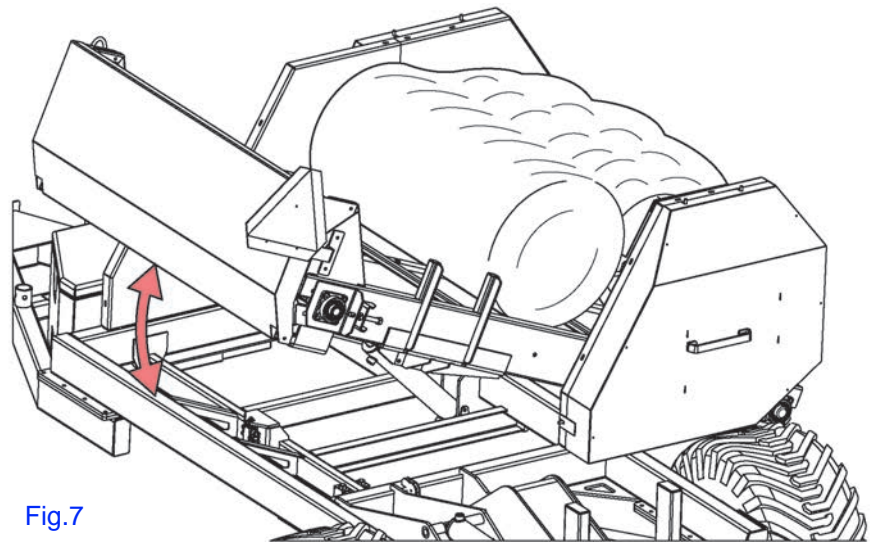



Fig.7

To remove a bale that will not unravel:

 **WARNING:** Ensure area is clear of bystanders before completing this operation.

1. Unlatch pins (A) on both sides of bed gate (B).
2. Swing bed gate down.
3. Reverse conveyor chain until bale is removed from bale bed.
4. Raise bed gate and lock with pins.

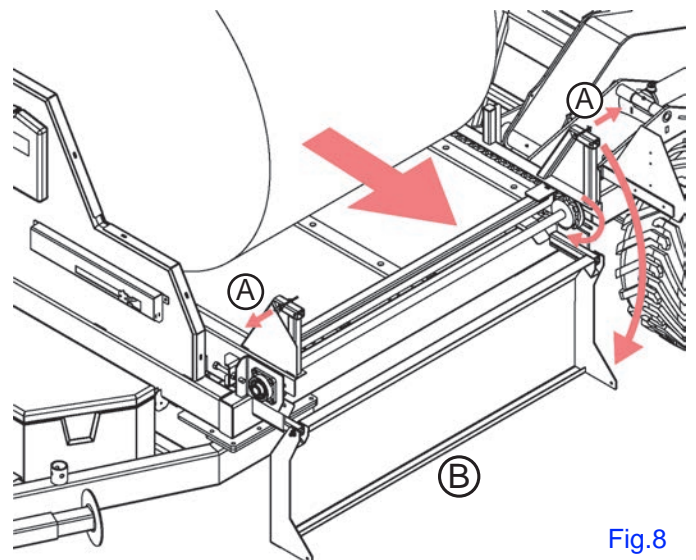

Fig.8

Section 6: Maintenance

This section gives full details of the procedures necessary to maintain the Tubeline Self Loading Bale Feeder at peak efficiency. Complete all checks and services in this section at the hour interval shown.

NOTE: Failure to complete the required maintenance at the interval shown can cause unnecessary downtime.

The recommended lubrication intervals are for average conditions. Perform lubrication more often when operating under adverse conditions.



WARNING: Before lubricating the BF8000SL Bale Feeder always observe the following precautions:

Turn off tractor, set parking brake, remove key and wait for all moving parts to stop before leaving cab. Failure to comply could result in death or serious injury.

Grease Points

ITEM	AREA	TIMELINE
A	Rear Roller Chain - Aerosal Lithium Chain Lubricant	Weekly
B	Front Roller Chain (x2) - Aerosal Lithium Chain Lubricant	Weekly
C	Bearings (x4) - Lithium Complex Grease	3 pumps / 50 hours
D	Hubs (x2) - Lithium Complex Grease	3 pumps / 50 hours
E	Cylinder Pivots (x8) - Lithium Complex Grease	3 pumps / 50 hours

Grease Point Locations

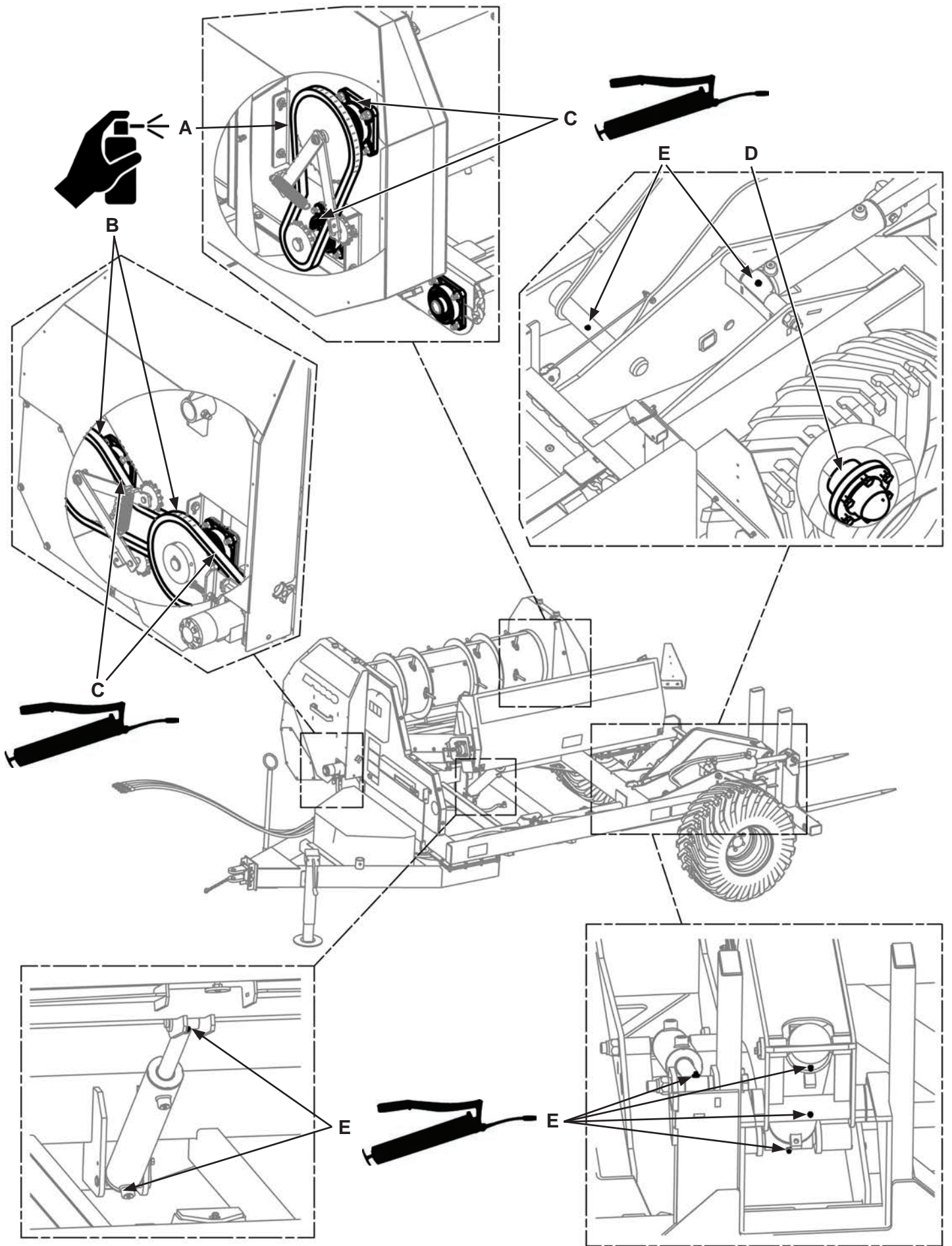



WARNING: Before performing any adjustments or maintenance on the Tube-Line BF8000SL, observe these safety precautions:

Turn off tractor, set parking brake, remove key and wait for all moving parts to stop before leaving cab.

Read *Maintenance Safety, pg.2-2*.

Failure to comply could result in death or serious injury.

Daily Maintenance

Careful inspection and service of the Bale Feeder prior to operation each day will prevent needless breakdowns and delays in the field. Make the following checks and adjustments.

1. Be alert for loose hardware and tighten or replace as required.
2. Lubricate the BF8000SL according to the instruction in the “Grease Points” section of this manual.

Preseason Service

Prior to beginning the harvest after offseason storage, take the following steps be certain the Tube-line BF8000SL is in good condition.

Check that chains are not slack, tighten if needed using adjustments shown on *pg.4-2*.

Lubricate the Tube-line BF8000SL according to *Grease Points, pg.6-1*.

General checking of bolts, security pins and split pins must be carried out initially after the first 8 hours of use. Subsequently, check every 50 hours and whenever the machine is laid up for extended periods.

End of Season Service

Prior to storing the Tube-line BF5000 during the off season, follow these steps to ensure easier preparation for the next season and longer Tube-line BF8000SL life.

- Pack all grease points with grease. Refer to *Grease Points, pg.6-1*.
- Remove all crop material from the BF8000SL.

Section 8: Parts Breakdowns & Lists

Illustrations may differ slightly from actual machine.

Frame

ITEM	QTY	PART NUMBER	DESCRIPTION	NOTE
1	1	25261	Safety Chain 10000 # 59"	
2	1	25719	Heavy Duty Jack	
3	1	40649	Clevis Hitch	
4	1	49632	Trailer Box	
5	1	49697	Hitch Weldment	
6	1	49706	Base Frame Weldment	
7	1	49796	Left Side Axle	
8	1	49797	Right Side Axle	
9	1	BF5000-SL-11	Hose Support	
10	32	HB1/2-13X1.75Z5	Hex Bolt 1/2-13x1 3/4 Grade 5 Zinc Plated Hex Cap Screw	
11	2	HB3/4-10X5.5Z5	Hex Bolt 3/4-10x5 1/2 Grade 5 Zinc Plated Hex Cap Screw	
12	4	HB3/8-16X0.75Z5	Hex Bolt 3/8-16x3/4 Grade 5 Zinc Plated Hex Cap Screw	
13	2	HUB 6000#	Hub Assembly HUB6000	Inc. Items 14-24
14	6	BS208134	Wheel Bolt 9/16 x 1-3/4	
15	1	PP00527	Hub Only - 6000#	
16	1	PP00528	Dust Cap D6000 Hub (HUB D6000)	
17	1	HUB 6000-CCS	Seals and Bearing Kit HUB6000	Items 18-22
18	1	PP00529	Seal LP140 - Grease Seal - (CR20148)	
19	1	PP00530	Inner Cone	
20	1	PP00531	Outer Cone	
21	1	PP00532	Outer Cup	
22	1	PP00533	Inner Cup	
23	1	HNC1.0-12FB5	Hex Nut 1"-12 Slotted Plain Finish (NF Castle Nut Bare)	
24	1	FW 1.0	Flatwasher - 1" Zinc Plated USS	
25	1	CP 3/16 X 2	Pin,Cotter - 3/16" X 2" Zinc Finish Extended Prong	
26	32	LN1/2-13NCZ5	LN 1/2-13 Zinc Plated Nylon Insert Lock Nut	
27	2	LN3/4-10NCZ5	LN 3/4-10 Zinc Plated Nylon Insert Lock Nut	
28	4	LN3/8-16NCZ5	LN 3/8-16 Zinc Plated Nylon Insert Lock Nut	
29	1	LP B1997	Pin - Lock Pin 5/16 X 2 1/2	
30	2	WHE 400X60X15.5-6A	Wheel Assembly 400X60X15.5 - 6 Bolt	Inc. Items 30-31
31	1	WHE 15513	Rim - 15.5 x 13 (6 Bolt -1.00 Offset)	
32	1	WHE 400X60X15.5	Tire Only 400X60X15.5	

Inner Shielding

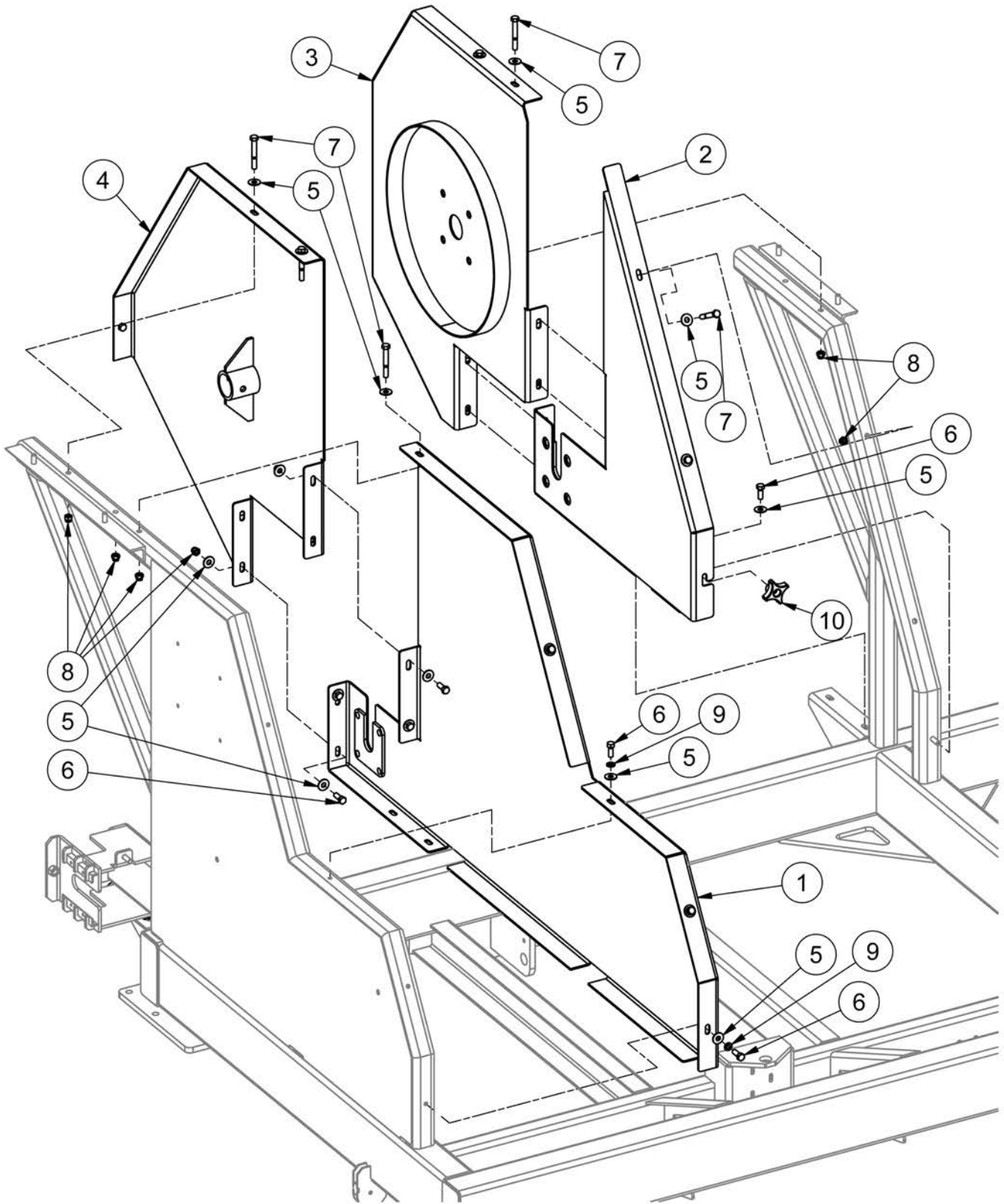

Inner Shielding

ITEM	QTY	PART NUMBER	DESCRIPTION
1	1	49629	Front Side Plate Weldment
2	1	49635	Back Side Plate Weldment
3	1	49661	Back Side Plate Weldment 2
4	1	49675	Front Side Plate Weldment 2
5	36	FW 3/8	Flatwasher - 3/8" Zinc Plated USS
6	16	HB3/8-16X1Z5	Hex Bolt 3/8-16x1 Grade 5 Zinc Plated Hex Cap Screw
7	7	HB3/8-16X2.75Z5	Hex Bolt 3/8-16x2 3/4 Grade 5 Zinc Plated Hex Cap Screw
8	20	LN3/8-16NCZ5	LN 3/8-16 Zinc Plated Nylon Insert Lock Nut
9	4	LW 3/8	LW -3/8" Zinc Plated Medium Split

Bale Bed

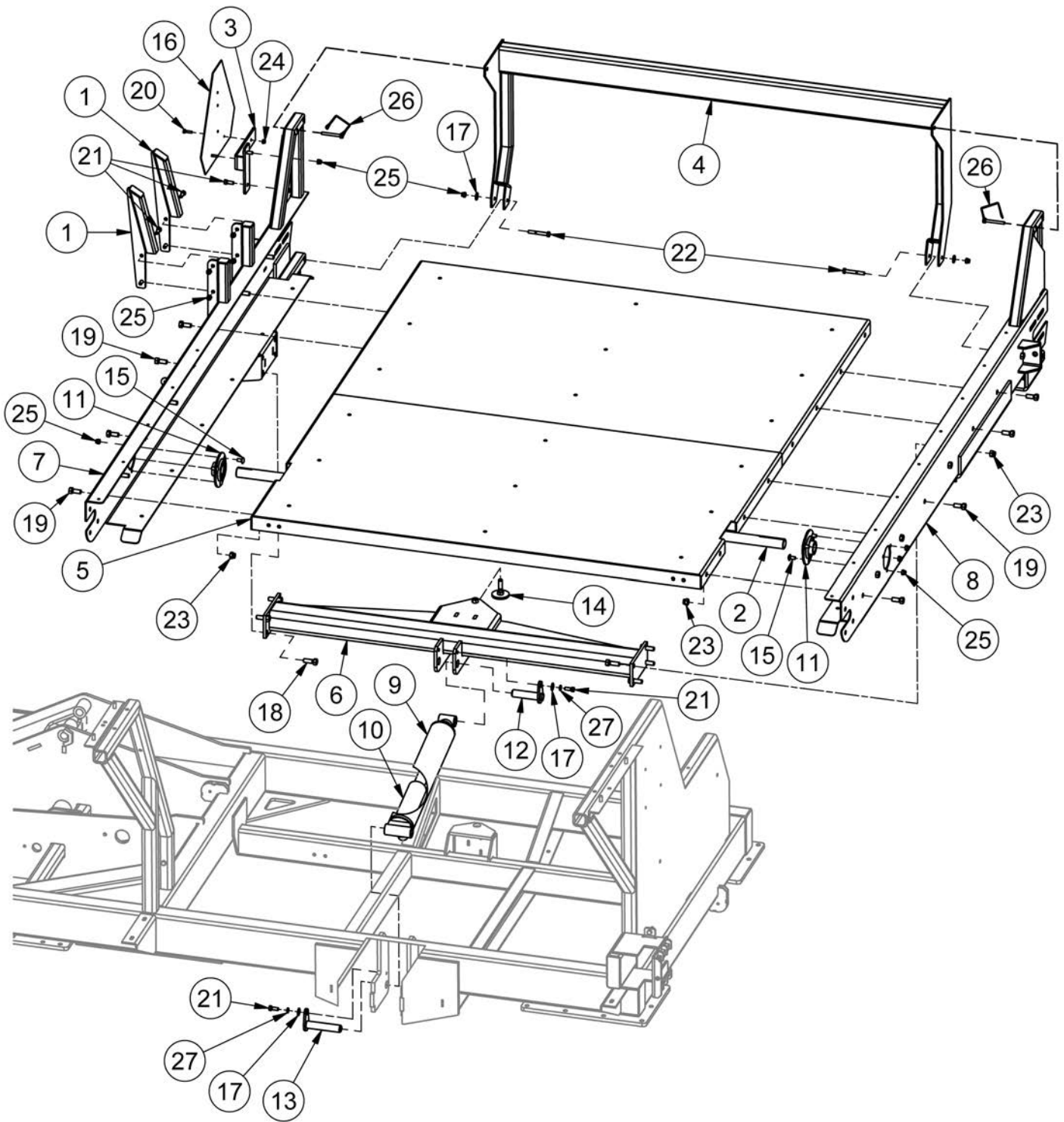

Bale Bed

ITEM	QTY	PART NUMBER	DESCRIPTION
1	2	47768	Bale Stop Extension
2	1	48101	Conveyor Pivot Shaft
3	1	48192	Slow Moving Vehicle Sign Bracket
4	1	48459	Rear Conveyor Shield
5	1	49671	Infeed Conveyor Bed Weldment
6	1	49688	Infeed Conveyor Cylinder HSS Wedment
7	1	49755	Infeed Conveyor Frame 2
8	1	49756	Infeed Conveyor Frame 1
9	1	49803	3" Bore x 16" Stroke Hydraulic Cylinder
10	1	50308	Cylinder Spacer
11	2	BEA 49939	BEA PF207 & BEA SA207-22
12	1	BF5000-A14	Bed Cylinder Pin
13	1	BF5000-A15	Frame Cylinder Pin
14	1	BF5000-A16	Stop Pad
15	6	CB3/8-16X0.75CZ5	Carriage Bolt - 3/8-16 x 3/4" Grade 5 Zinc
16	1	DESMV	Slow Moving Vehicle Sign
17	5	FW 3/8	Flatwasher - 3/8" Zinc Plated USS
18	8	HB1/2-13X1.5Z5	Hex Bolt 1/2-13x1 1/2 Grade 5 Zinc Plated Hex Cap Screw
19	16	HB1/2-13X1.25Z5	Hex Bolt 1/2-13x1 1/4 Grade 5 Zinc Plated Hex Cap Screw
20	2	HB1/4-20X1Z5	Hex Bolt 1/4-20x1 Grade 5 Zinc Plated Hex Cap Screw
21	12	HB3/8-16X1Z5	Hex Bolt 3/8-16x1 Grade 5 Zinc Plated Hex Cap Screw
22	2	HB3/8-16X2.75Z5	Hex Bolt 3/8-16x2 3/4 Grade 5 Zinc Plated Hex Cap Screw
23	24	LN1/2-13NCZ5	LN 1/2-13 Zinc Plated Nylon Insert Lock Nut
24	2	LN1/4-20NCZ5	LN 1/4-20 Zinc Plated Nylon Insert Lock Nut
25	20	LN3/8-16NCZ5	LN 3/8-16 Zinc Plated Nylon Insert Lock Nut
26	2	LP B1997	Pin - Lock Pin 5/16 X 2 1/2
27	2	LW 3/8	LW -3/8" Zinc Plated Medium Split

Bale Bed Conveyor

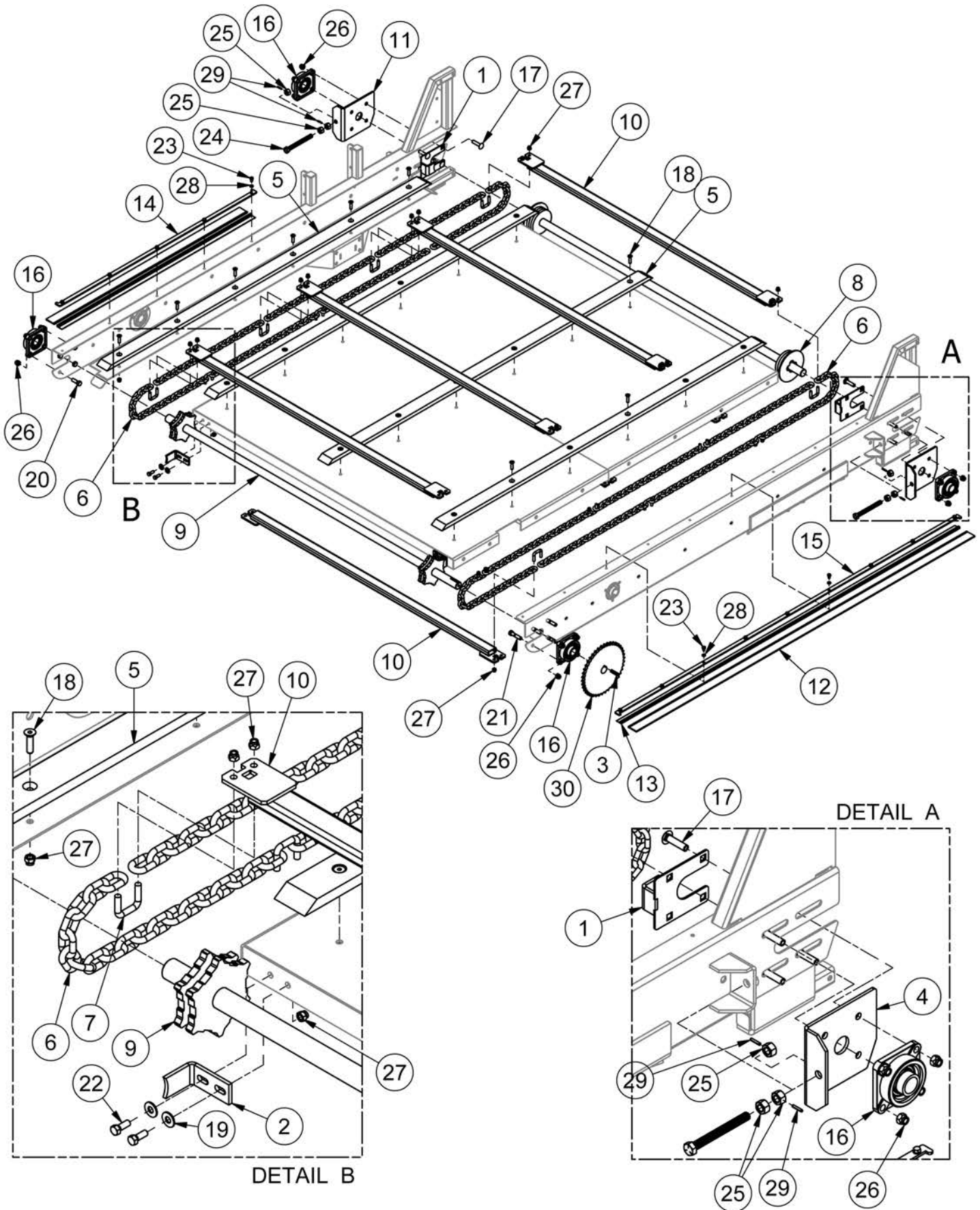

Bale Bed Conveyor

ITEM	QTY	PART NUMBER	DESCRIPTION
1	2	47986	Idler Shaft Scraper
2	2	48100	Sprocket Clean Out Plate
3	1	48122	5/16" x 5/16" x 1-3/4" Keystock
4	1	49616	Conveyor Bearing Take Up Plate
5	5	49657	Infeed Conveyor Chain Wear Strip 1
6	2	49658	GR.70 Chain Assembly
7	14	49660	Gr 70 Chain U-Bolt
8	1	49680	Infeed Conveyor 1 Tail Shaft Weldment
9	1	49685	Infeed Conveyor 1 Drive Shaft Weldment
10	7	49694	Conveyor Slat
11	1	50361	Conveyor Bearing Take Up Plate (Mirror)
12	1	51226	2" Nylon Brush 84" Long
13	1	51227	Aluminum Brush Holder 84" Long
14	1	51228	Brush Mount Plate 48" Long
15	1	51229	Brush Mount Plate 84" Long
16	4	BEA UCF207-22	Flange Block, UCF207-22 1.38" Diameter, National 4-Bolt
17	8	CB1/2-13X2CZ5	Carriage Bolt - 1/2-13 x 2" Grade 5 Zinc
18	30	FHSCS3/8-16X1.5	Hex Bolt - 3/8"-16 x 1 1/2" Flat Socket Cap Screw
19	4	FW 3/8	Flatwasher - 3/8" Zinc Plated USS
20	4	HB1/2-13X1.5Z5	Hex Bolt 1/2-13x1 1/2 Grade 5 Zinc Plated Hex Cap Screw
21	4	HB1/2-13X2.25Z5	Hex Bolt 1/2-13x2 1/4 Grade 5 Zinc Plated Hex Cap Screw
22	4	HB3/8-16X1Z5	Hex Bolt 3/8-16x1 Grade 5 Zinc Plated Hex Cap Screw
23	14	HB5/16-24X0.5Z5	Hex Bolt 5/16-24x1/2 Grade 5 Zinc Plated Hex Cap Screw
24	2	HB5/8-11 X 6 TCZ5	5/8-11x6 UNC Fully Threaded Hex Bolt
25	6	HN5/8-11CZ5	Hex Nut 5/8"-11 Grade 5 Zinc Plated Finished
26	16	LN1/2-13NCZ5	LN 1/2-13 Zinc Plated Nylon Insert Lock Nut
27	62	LN3/8-16NCZ5	LN 3/8-16 Zinc Plated Nylon Insert Lock Nut
28	14	LW 5/16	LW -5/16" Zinc Plated Medium Split
29	4	RP 3/16 x 1	Pin - Roll Pin 3/16 x 1
30	1	SPR60B42F-1.38	Sprocket - 60B42F 1 3/8" KW 2SS 5/16 Keyway

Drum - Original Welded End

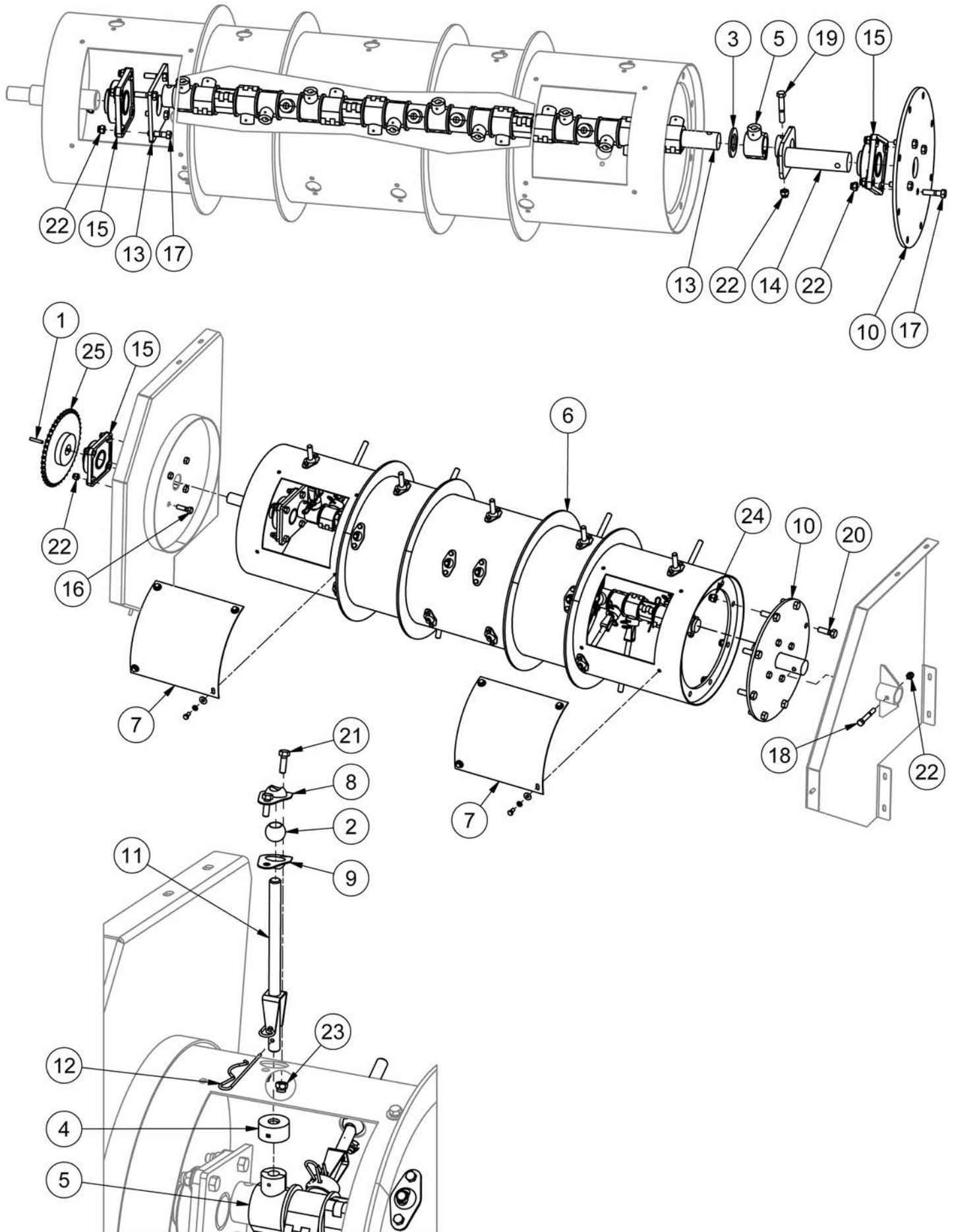

Drum - Original Welded End

Serial Numbers: 23BF8001, 23BF8002, 24BFSL8001 - 24BFSL8012,
24BFSL8015, 24BFSL8016, 24BFSL8018, 24BFSL8019, 24BFSL8022

ITEM	QTY	PART NUMBER	DESCRIPTION	NOTE
1*	1	48122	5/16" x 5/16" x 1-3/4" Keystock	
2	25	49619	Ball Bearing	
3	24	49641	Finger Holder Washer	
4	25	49642	Retainer	
5	25	49643	Finger Bearing	
6	1	49646	Finger Drum Weldment	Obsolete - Replace w 45179
7	3	49651	Finger Drum Access Cover	
8	25	49652	Ball Bearing Outer Retainer	
9	25	49653	Ball Bearing Inner Retainer	
10	1	49654	Finger Drum Removable End Plate	
11	25	49655	Steel Finger	
12	25	49656	Finger Locking Pin	
13	1	49667	Finger Cam Shaft Weldment	
14	1	49679	Finger Drum Idler Shaft Weldment	
15	3	BEA UCF210-32R3	2" 4 Bolt Flange Bearing	
16	4	HB1/2-13X1.75Z5	Hex Bolt 1/2-13x1 3/4 Grade 5 Zinc Plated Hex Cap Screw	
17	8	HB1/2-13X2Z5	Hex Bolt 1/2-13x2 Grade 5 Zinc Plated Hex Cap Screw	
18	1	HB1/2-13X3.5Z5	Hex Bolt 1/2-13x3 1/2 Grade 5 Zinc Plated Hex Cap Screw	
19	1	HB1/2-13X3Z5	Hex Bolt 1/2-13x3 Grade 5 Zinc Plated Hex Cap Screw	
20	8	HB5/8-11X2Z5	Hex Bolt 5/8-11x2 Grade 5 Zinc Plated Hex Cap Screw	
21	50	HB5/16-18X1Z5	Hex Bolt 5/16-18x1 Grade 5 Zinc Plated Hex Cap Screw	
22	14	LN1/2-13NCZ5	LN 1/2-13 Zinc Plated Nylon Insert Lock Nut	
23	50	LN3/8-16NCZ5	LN 3/8-16 Zinc Plated Nylon Insert Lock Nut	
24	8	LN5/8-11NCZ5	LN 5/8-11 Zinc Plated Nylon Insert Lock Nut	
25*	1	SPR60B42F-1.38	Sprocket - 60B42F 1 3/8" KW 2SS 5/16 Keyway	

* **Serial Numbers:** 23BF8002, 24BFSL8003, 24BFSL8010, 24BFSL8022 have SPR60B42F-2.0 and KS47985.

45179 - Finger Drum Update Kit

Updates 49646 to 45179. Greyed our parts are reused from original drum.

Serial Numbers: 23BF8001, 23BF8002, 24BFSL8001 - 24BFSL8012,
24BFSL8015, 24BFSL8016, 24BFSL8018, 24BFSL8019, 24BFSL8022.

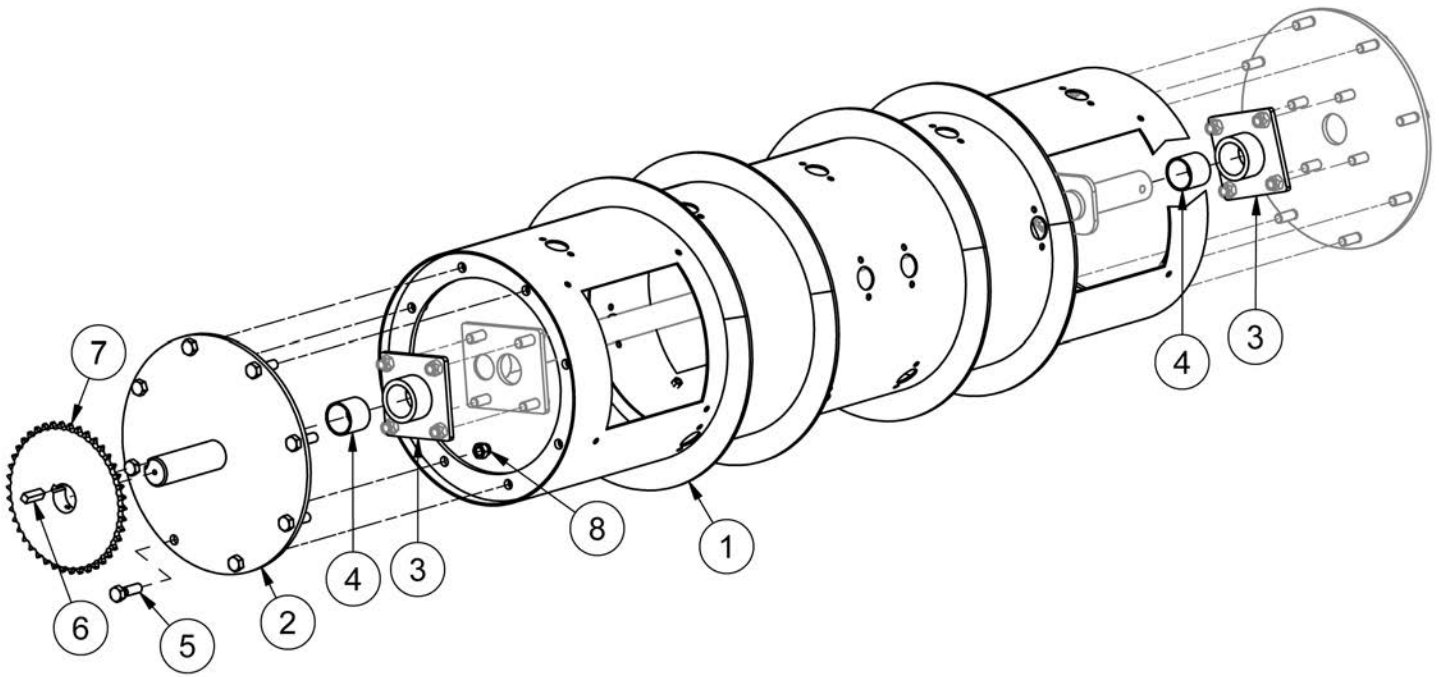

45179 - Finger Drum Update Kit

Updates 49646 to 45179. Greyed our parts are reused from original drum.

Serial Numbers: 23BF8001, 23BF8002, 24BFSL8001 - 24BFSL8012, 24BFSL8015, 24BFSL8016, 24BFSL8018, 24BFSL8019, 24BFSL8022.

ITEM	QTY	PART NUMBER	DESCRIPTION	NOTE
1	1	48427	Finger Drum Weldment	Replaces 49646
2	1	48428	Finger Drum Drive End	
3	2	48430	Inner Drum Bearing	Replaces BEA UCF210-32R3
4	2	48458	Igus 2.25 OD x 2 ID x 2 LG Bushing	Replaces BEA UCF210-32R3
5	8	HB5/8-11X2Z5	Hex Bolt 5/8-11x2 Gr.5 Zinc Plated Hex Cap Screw	
6	1	KS47985	1/2" x 1/2" x 1-3/4" Keystock	
8	24	LN5/8-11NCZ5	LN 5/8-11 Zinc Plated Nylon Insert Lock Nut	Replaces 48122
7	1	SPR60B42F-2.0	Sprocket - 60B42F 2.0" Bore 2SS 1/2" Keyway	Replaces SPR60B42F-1.38

Drum - Current

Serial Numbers: , 24BFSL8003, 24BFSL8013,
24BFSL8014, 24BFSL8017, 24BFSL8020 - Current

ITEM	QTY	PART NUMBER	DESCRIPTION
1	1	48427	Finger Drum Weldment
2	1	48428	Finger Drum Drive End
3	2	48430	Inner Drum Bearing
4	2	48458	Igus 2.25 OD x 2 ID x 2 LG Bushing
5	25	49619	Ball Bearing
6	24	49641	Finger Holder Washer
7	25	49642	Retainer
8	25	49643	Finger Bearing
9	3	49651	Finger Drum Access Cover
10	25	49652	Ball Bearing Outer Retainer
11	25	49653	Ball Bearing Inner Retainer
12	1	49654	Finger Drum Removable End Plate
13	1	49655	Steel Finger
14	1	50765	Steel Finger Retainer
15	1	50766	Steel Auger Finger Retainer Pin
16	25	49656	Finger Locking Pin
17	1	49667	Finger Cam Shaft Weldment
18	1	49679	Finger Drum Idler Shaft Weldment
19	1	BEA UCF210-32R3	2" 4 Bolt Flange Bearing
20	12	FW 3/8	Flatwasher - 3/8" Zinc Plated USS
21	1	HB1/2-13X3.5Z5	Hex Bolt 1/2-13x3 1/2 Grade 5 Zinc Plated Hex Cap Screw
22	1	HB1/2-13X3Z5	Hex Bolt 1/2-13x3 Grade 5 Zinc Plated Hex Cap Screw
23	12	HB3/8-16X0.75Z5	Hex Bolt 3/8-16x3/4 Grade 5 Zinc Plated Hex Cap Screw
24	8	HB5/8-11X1.75Z5	Hex Bolt 5/8-11x1 3/4 Grade 5 Zinc Plated Hex Cap Screw
25	16	HB5/8-11X2Z5	Hex Bolt 5/8-11x2 Grade 5 Zinc Plated Hex Cap Screw
26	50	HB5/16-18X1Z5	Hex Bolt 5/16-18x1 Grade 5 Zinc Plated Hex Cap Screw
27	1	KS47985	1/2" X 1/2" X 1-3/4" Keystock
28	2	LN1/2-13NCZ5	LN 1/2-13 Zinc Plated Nylon Insert Lock Nut
29	50	LN3/8-16NCZ5	LN 3/8-16 Zinc Plated Nylon Insert Lock Nut
30	28	LN5/8-11NCZ5	LN 5/8-11 Zinc Plated Nylon Insert Lock Nut
31	12	LW 3/8	LW -3/8" Zinc Plated Medium Split
32	1	SPR60B42F-2.0	Sprocket - 60B42F 2.0" Bore 2SS 1/2" Keyway

Front Chain Drive - Original

Serial Numbers: 23BF8001-24BFSL8009, 24BFSL8011, 24BFSL8012, 24BFSL8015, 24BFSL8016, 24BFSL8018, 24BFSL8019, 24BFSL8022.

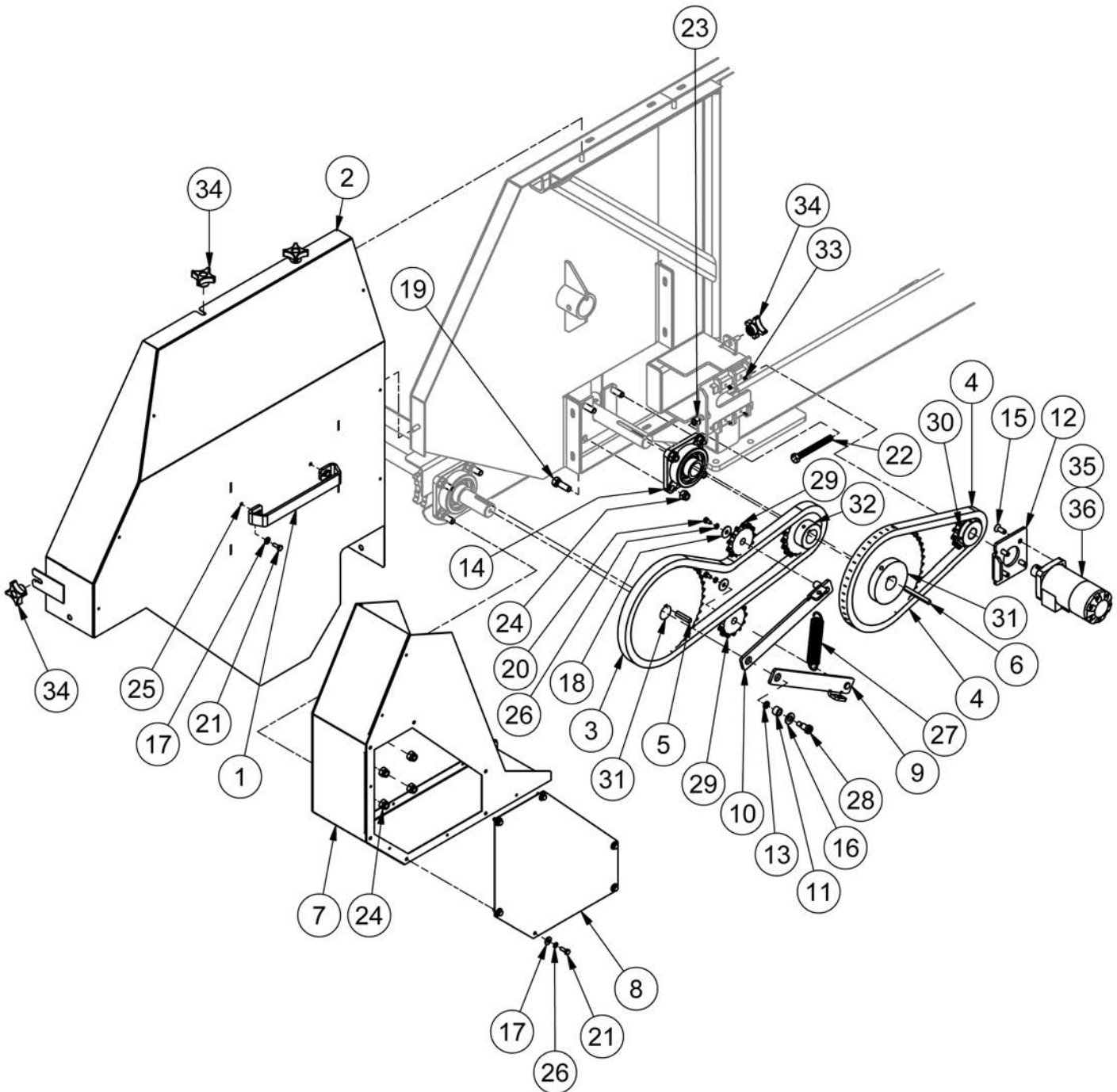

Front Chain Drive - Original

Serial Numbers: 23BF8001-24BFSL8009, 24BFSL8011, 24BFSL8012, 24BFSL8015, 24BFSL8016, 24BFSL8018, 24BFSL8019, 24BFSL8022.

ITEM	QTY	PART NUMBER	DESCRIPTION
1	1	44858	Door Handle
2	1	48113	Drive Cover
3	1	48118	#60 Roller Chain
4	1	48120	#60 Roller Chain
5	1	48122	5/16" x 5/16" x 1-3/4" Keystock
6	1	48123	5/16" x 5/16" x 3-1/8" Keystock
7	1	48127	Conveyor Guard
8	1	48132	Access Hatch
9	1	50302	Chain Tensioning Bracket 1
10	1	50303	Chain Tensioning Bracket 2
11	1	50312	Chain Tensioning Arm Bearing
12	1	50478	Motor Mount Plate
13	1	50751	Nord-Lock Wwasher 3/8" Dia Std OD
14	1	BEA UCF207-22	Flange Block, UCF207-22 1.38" Diameter, National 4-Bolt Ductile
15	4	FHSCS3/8-16X1	Hex Bolt - 3/8"-16 x 1" Flat Socket Cap Screw
16	1	FW 1/2	Flatwasher - 1/2" Zinc Plated USS
17	8	FW 1/4	Flatwasher - 1/4" Zinc Plated USS
18	2	FW 5/16	Flatwasher - 5/16" Zinc Plated USS
19	4	HB1/2-13X1.5Z5	Hex Bolt 1/2-13x1 1/2 Grade 5 Zinc Plated Hex Cap Screw
20	2	HB1/4-20X0.5Z5	Hex Bolt 1/4-20x1/2 Grade 5 Zinc Plated Hex Cap Screw
21	8	HB1/4-20X0.75Z5	Hex Bolt 1/4-20x3/4 Grade 5 Zinc Plated Hex Cap Screw
22	1	HB1/2-13X4.1/2TCZ5	1/2-13 x 4-1/2 UNC Fully Threaded Hex Bolt
23	1	HN1/2-13CZ5	Hex Nut 1/2"-13 Grade 5 Zinc Plated Finished
24	12	LN1/2-13NCZ5	LN 1/2-13 Zinc Plated Nylon Insert Lock Nut
25	2	LN1/4-20NCZ5	LN 1/4-20 Zinc Plated Nylon Insert Lock Nut
26	8	LW 1/4	LW - 1/4" Zinc Plated Medium Split
27	1	PP00695	Spring 2-TE 89B
28	1	SHSS1/2X5/8X3/8-16Z	Socket Head Shoulder Screws - 1/2 Shldr x 5/8 x 3/8-16
29	2	SPR60A13-.625	#60, 13 Tooth, .625 Bearing Idler Sprocket
30	1	SPR60B14-1	Sprocket 60B14 1.0 Bore Idler 1/4 Keyway- 2 Set Screws
31	2	SPR60B42F-1.38	Sprocket - 60B42F 1 3/8" KW 2SS 5/16 Keyway
32	1	SPR60B201.375	20 Tooth # 60 Sprocket with Hub
33	4	SS1/4-20CX0.25CP	Allan Head Set Screw, 1/4-20 x 1/4
34	4	TL599-100-104	Switch Adjuster Screw (4 Prong Knob)
35	1	VAL 1008	Motor, Hydraulic - EAT101-1008-009
36	1	SKMLHPQUDE	Seal Kit - 200400 Series Motors (MLHPQ-U/D)

Front Chain Drive - Current

Serial Numbers: 24BFSL8010, 24BFSL8013, 24BFSL8014, 24BFSL8017, 24BFSL8020, 24BFSL8021, 24BFSL8023 - Current.

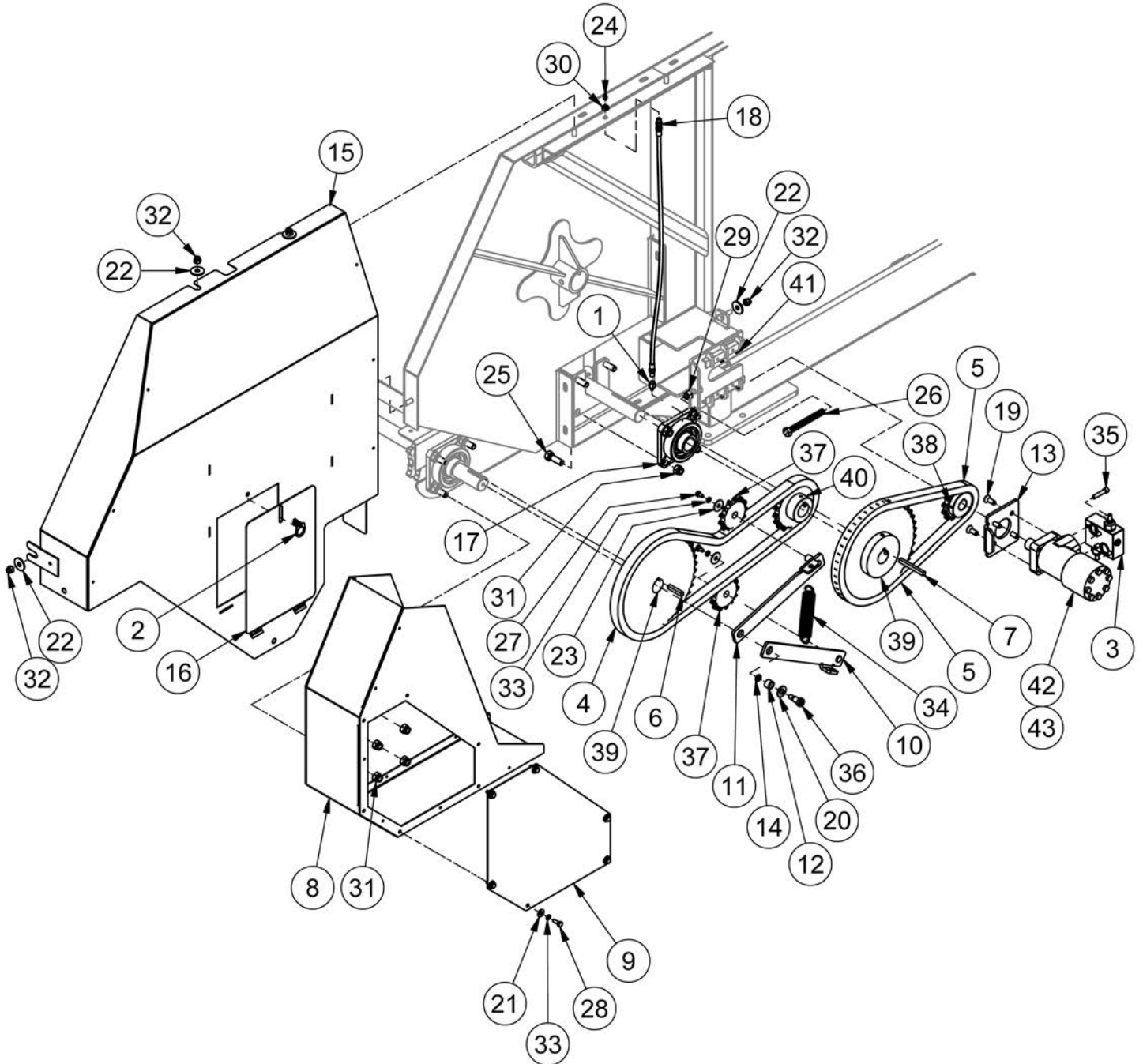

Front Chain Drive - Current

ITEM	QTY	PART NUMBER	DESCRIPTION
1	1	35617	Grease Line Adapter 1/4 - 28 Male to 1/8 - 27 NPT Female
2	1	36268	Cam Lock
3	1	47996	Hydraulic Cross Port Relief for Motor
4	1	48118	#60 Roller Chain
5	1	48120	#60 Roller Chain
6	1	48122	5/16" x 5/16" x 1-3/4" Keystock
7	1	48123	5/16" x 5/16" x 3-1/8" Keystock
8	1	48127	Conveyor Guard
9	1	48132	Access Hatch
10	1	50302	Chain Tensioning Bracket 1
11	1	50303	Chain Tensioning Bracket 2
12	1	50312	Chain Tensioning Arm Bearing
13	1	50478	Motor Mount Plate
14	1	50751	Nord-Lock Wwasher 3/8" Dia Std OD
15	1	51220	Drive Cover
16	1	51223	Inspection Door Plate
17	1	BEA UCF207-22	Flange Block, UCF207-22 1.38" Diameter, National 4-Bolt Ductile
18	1	51232	HH2R7(2MPX,2GKCY) HCL 28"
19	4	FHSCS3/8-16X1	Hex Bolt - 3/8"-16 x 1" Flat Socket Cap Screw
20	1	FW 1/2	Flatwasher - 1/2" Zinc Plated USS
21	6	FW 1/4	Flatwasher - 1/4" Zinc Plated USS
22	7	FW 3/8	Flatwasher - 3/8" Zinc Plated USS
23	2	FW 5/16	Flatwasher - 5/16" Zinc Plated USS
24	1	GR 1/4 X 28	Grease Fitting 1/4-28 Straight Standard Zerk
25	4	HB1/2-13X1.5Z5	Hex Bolt 1/2-13x1 1/2 Grade 5 Zinc Plated Hex Cap Screw
26	1	HB1/2-13X4.1/2TCZ5	1/2-13 x 4-1/2 UNC Fully Threaded Hex Bolt
27	2	HB1/4-20X0.5Z5	Hex Bolt 1/4-20x1/2 Grade 5 Zinc Plated Hex Cap Screw
28	6	HB1/4-20X0.75Z5	Hex Bolt 1/4-20x3/4 Grade 5 Zinc Plated Hex Cap Screw
29	1	HN1/2-13CZ5	Hex Nut 1/2"-13 Grade 5 Zinc Plated Finished
30	1	HNJ3/8-16	Hex Nut - 3/8-16 Zinc Plated Hex Jam Nut
31	12	LN1/2-13NCZ5	LN 1/2-13 Zinc Plated Nylon Insert Lock Nut
32	4	LN3/8-16NCZ5	LN 3/8-16 Zinc Plated Nylon Insert Lock Nut
33	8	LW 1/4	LW - 1/4" Zinc Plated Medium Split
34	1	PP00695	Spring 2-TE 89B
35	4	SHCS5/16-18X1.5	Hex Bolt - 5/16-18 x 1 1/2 Socket Head Cap Screw
36	1	SHSS1/2X5/8X3/8-16Z	Socket Head Shoulder Screws - 1/2 Shldr x 5/8 x 3/8-16
37	2	SPR60A13-.625	#60, 13 Tooth, .625 Bearing Idler Sprocket
38	1	SPR60B14-1	Sprocket 60B14 1.0 Bore Idler 1/4 Keyway- 2 Set Screws
39	2	SPR60B42F-1.38	Sprocket - 60B42F 1 3/8" KW 2SS 5/16 Keyway
40	1	SPR60B201.375	20 Tooth # 60 Sprocket with Hub
41	4	SS1/4-20CX0.25CP	Allan Head Set Screw, 1/4-20 x 1/4
42	1	VAL 1008	Motor, Hydraulic - (BS208107A)
43	1	SKMLHPQUDE	Seal Kit - 200400 Series Motors (MLHPQ-U/D)

Rear Apron Chain - Original

Serial Numbers: 23BF8001-24BFSL8009, 24BFSL8011, 24BFSL8012, 24BFSL8015, 24BFSL8016, 24BFSL8018, 24BFSL8019, 24BFSL8022.

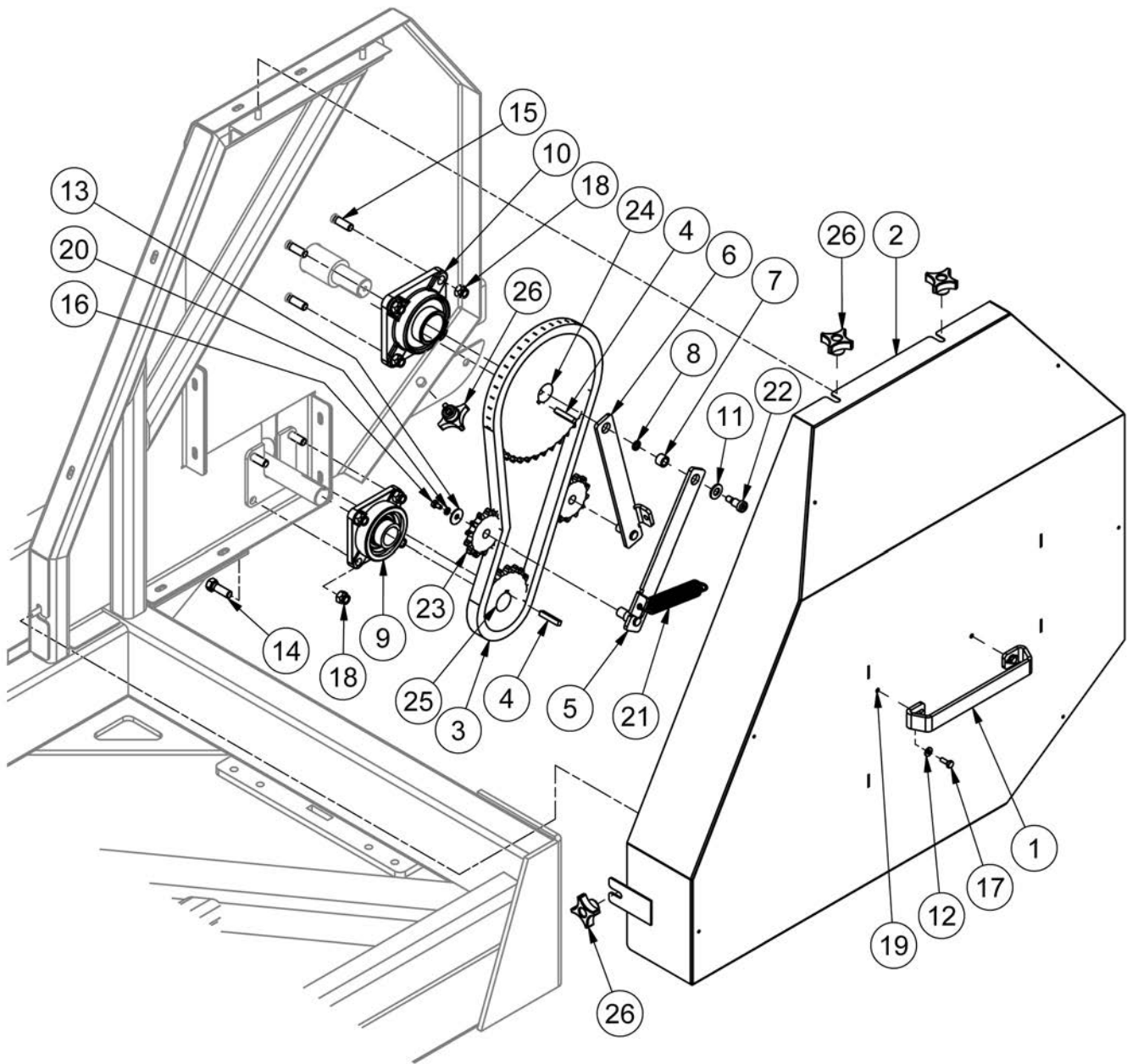

Rear Apron Chain - Original

Serial Numbers: 23BF8001-24BFSL8009, 24BFSL8011, 24BFSL8012, 24BFSL8015, 24BFSL8016, 24BFSL8018, 24BFSL8019, 24BFSL8022.

ITEM	QTY	PART NUMBER	DESCRIPTION
1	1	44858	Door Handle
2	1	48108	Bearing Guard
3	1	48119	#60 Roller Chain
4	2	48122	5/16" x 5/16" x 1-3/4" Keystock
5	1	50302	Chain Tensioning Bracket 1
6	1	50303	Chain Tensioning Bracket 2
7	1	50312	Chain Tensioning Arm Bearing
8	1	50751	Nord-Lock Washer 3/8" Dia Std OD
9	1	BEA UCF207-22	Flange Block, UCF207-22 1.38" Diameter, National 4-Bolt Ductile
10	1	BEA UCF210-32R3	2" Bearing 4-Bolt Ductile Iron Flange with Triple Seal
11	1	FW 1/2	Flatwasher - 1/2" Zinc Plated USS
12	2	FW 1/4	Flatwasher - 1/4" Zinc Plated USS
13	2	FW 5/16	Flatwasher - 5/16" Zinc Plated USS
14	4	HB1/2-13X1.5Z5	Hex Bolt 1/2-13x1 1/2 Grade 5 Zinc Plated Hex Cap Screw
15	4	HB1/2-13X1.75Z5	Hex Bolt 1/2-13x1 3/4 Grade 5 Zinc Plated Hex Cap Screw
16	2	HB1/4-20X0.5Z5	Hex Bolt 1/4-20x1/2 Grade 5 Zinc Plated Hex Cap Screw
17	2	HB1/4-20X0.75Z5	Hex Bolt 1/4-20x3/4 Grade 5 Zinc Plated Hex Cap Screw
18	8	LN1/2-13NCZ5	LN 1/2-13 Zinc Plated Nylon Insert Lock Nut
19	2	LN1/4-20NCZ5	LN 1/4-20 Zinc Plated Nylon Insert Lock Nut
20	2	LW 1/4	LW - 1/4" Zinc Plated Medium Split
21	1	PP00695	Spring 2-TE 89B
22	1	SHSS1/2X5/8X3/8-16Z	Socket Head Shoulder Screws - 1/2 Shldr x 5/8 x 3/8-16
23	2	SPR60A13-.625	#60, 13 Tooth, .625 Bearing, Idler Sprocket
24	1	SPR60B42F-1.38	Sprocket - 60B42F 1 3/8" KW 2SS 5/16 Keyway
25	1	SPR60B201.375	20 Tooth # 60 Sprocket with Hub
26	4	TL599-100-104	Switch Adjuster Screw (4 Prong Knob)

Rear Apron Chain - Current

Serial Numbers: 24BFSL8010, 24BFSL8013, 24BFSL8014, 24BFSL8017, 24BFSL8020, 24BFSL8021, 24BFSL8023 - Current.

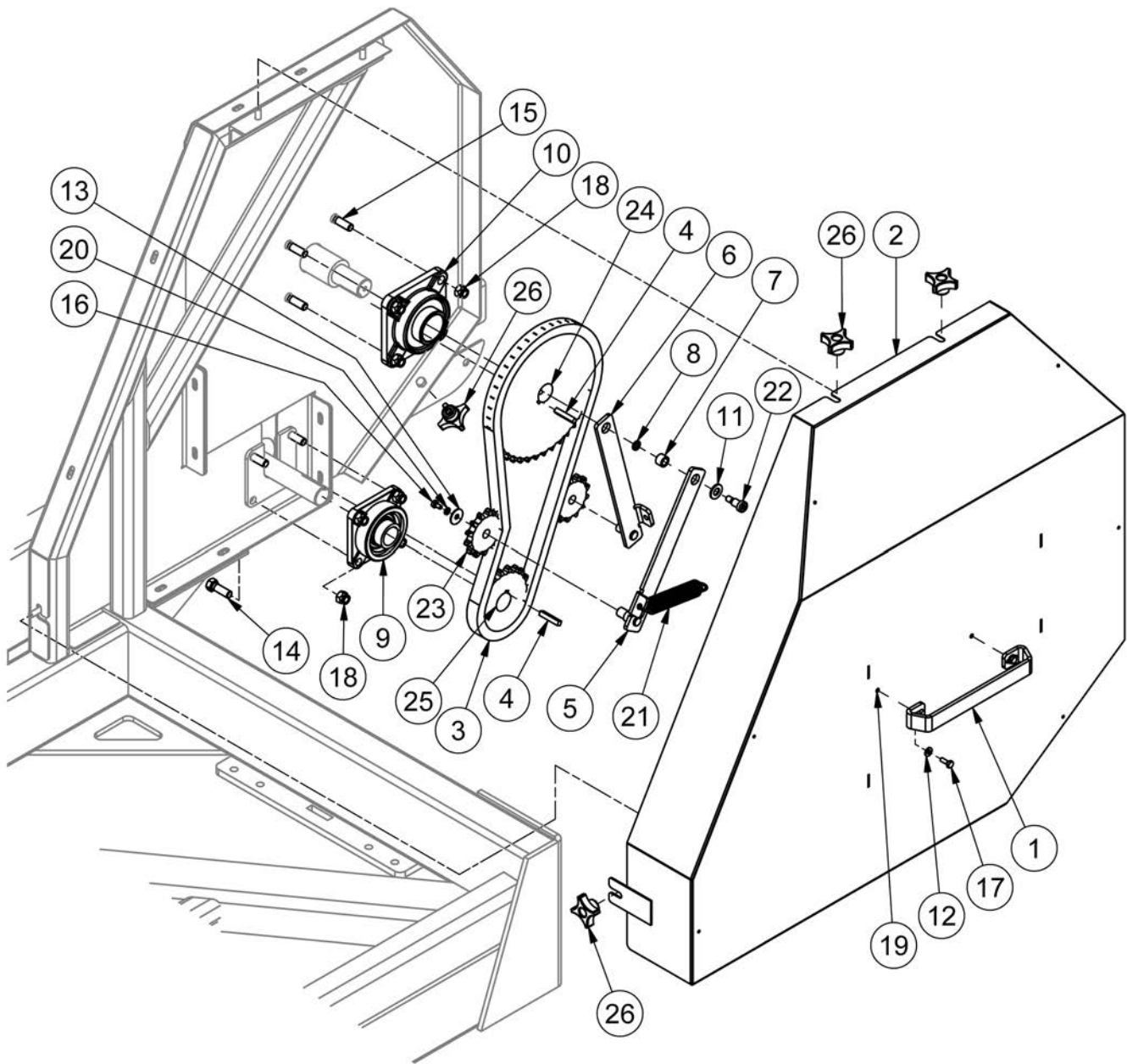

Rear Apron Chain - Current

ITEM	QTY	PART NUMBER	DESCRIPTION
1	1	44858	Door Handle
2	1	48108	Bearing Guard
3	1	48119	#60 Roller Chain
4	2	48122	5/16" x 5/16" x 1-3/4" Keystock
5	1	50302	Chain Tensioning Bracket 1
6	1	50303	Chain Tensioning Bracket 2
7	1	50312	Chain Tensioning Arm Bearing
8	1	50751	Nord-Lock Washer 3/8" Dia Std OD
9	1	BEA UCF207-22	Flange Block, UCF207-22 1.38" Diameter, National 4-Bolt Ductile
10	1	BEA UCF210-32R3	2" Bearing 4-Bolt Ductile Iron Flange with Triple Seal
11	1	FW 1/2	Flatwasher - 1/2" Zinc Plated USS
12	2	FW 1/4	Flatwasher - 1/4" Zinc Plated USS
13	2	FW 5/16	Flatwasher - 5/16" Zinc Plated USS
14	4	HB1/2-13X1.5Z5	Hex Bolt 1/2-13x1 1/2 Grade 5 Zinc Plated Hex Cap Screw
15	4	HB1/2-13X1.75Z5	Hex Bolt 1/2-13x1 3/4 Grade 5 Zinc Plated Hex Cap Screw
16	2	HB1/4-20X0.5Z5	Hex Bolt 1/4-20x1/2 Grade 5 Zinc Plated Hex Cap Screw
17	2	HB1/4-20X0.75Z5	Hex Bolt 1/4-20x3/4 Grade 5 Zinc Plated Hex Cap Screw
18	8	LN1/2-13NCZ5	LN 1/2-13 Zinc Plated Nylon Insert Lock Nut
19	2	LN1/4-20NCZ5	LN 1/4-20 Zinc Plated Nylon Insert Lock Nut
20	2	LW 1/4	LW - 1/4" Zinc Plated Medium Split
21	1	PP00695	Spring 2-TE 89B
22	1	SHSS1/2X5/8X3/8-16Z	Socket Head Shoulder Screws - 1/2 Shldr x 5/8 x 3/8-16
23	2	SPR60A13-.625	#60, 13 Tooth, .625 Bearing, Idler Sprocket
24	1	SPR60B42F-1.38	Sprocket - 60B42F 1 3/8" KW 2SS 5/16 Keyway
25	1	SPR60B201.375	20 Tooth # 60 Sprocket with Hub
26	4	TL599-100-104	Switch Adjuster Screw (4 Prong Knob)

Loading Arm

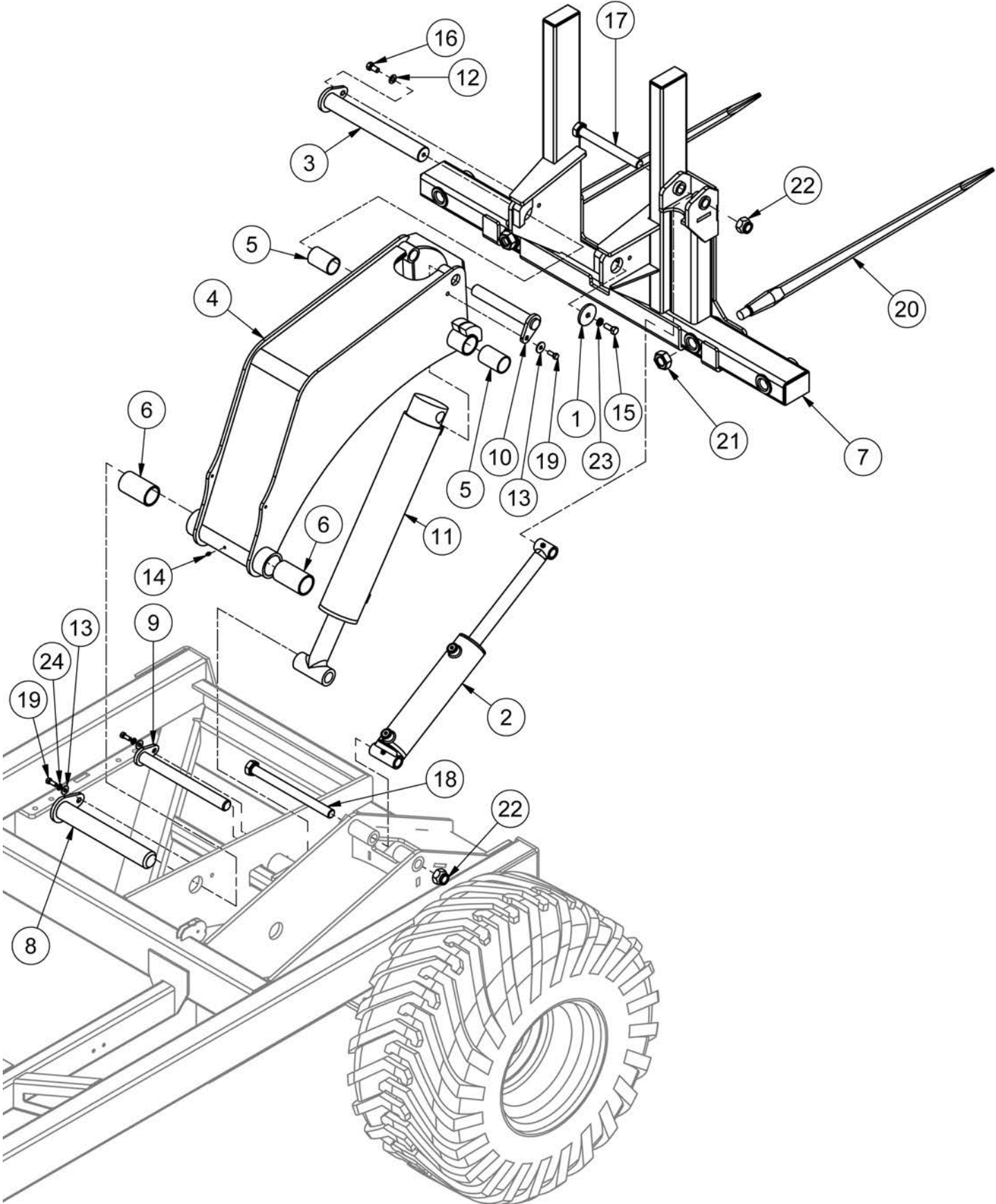

Loading Arm

ITEM	QTY	PART NUMBER	DESCRIPTION	NOTE
1	1	48102	Pin Stop Washer	
2	1	49916	3" Bore x 10" Stroke Hydraulic Cylinder	
3	1	49923	Fork Pin	
4	1	49927	Loader Arm	Incl Items 4,5
5	2	BF-5000-239	Fork Bushing	
6	2	BF-5000-240	Arm Pivot Bushing	
7	1	49929	Fork Frame	
8	1	BF5000-A08	Loader Arm Pin	
9	1	BF5000-A11	Loader Cyl - Bottom Pin	
10	1	BF5000-A12	Loader Top Cylinder Pin	
11	1	CYL-4001901	4" Bore x 19" Stroke Hydraulic Cylinder	
12	1	FW 1/2	Flatwasher - 1/2" Zinc Plated USS	
13	3	FW 3/8	Flatwasher - 3/8" Zinc Plated USS	
14	2	GR 1/4 X 28	Grease Fitting 1/4-28 Straight Standard Zerk	
15	1	HB1/2-13X1.25Z5	Hex Bolt 1/2-13x1 1/4 Grade 5 Zinc Plated Hex Cap Screw	
16	1	HB1/2-13X1Z5	Hex Bolt 1/2-13x1 Grade 5 Zinc Plated Hex Cap Screw	
17	1	HB1-8X9YZ8	Hex Bolt 1-8x9 Grade 8 Zinc Hex Cap Screw	
18	1	HB1-8X12YZ8	Hex Bolt 1-8x12 Grade 8 Zinc Hex Cap Screw	
19	3	HB3/8-16X1Z5	Hex Bolt 3/8-16x1 Grade 5 Zinc Plated Hex Cap Screw	
20	2	LA-SDE32	Bale Spear - 32" Conus II	
21	2	LA-SDENU	Conus II Nut	
22	2	LN1-8NCZ5	LN 1-8 Zinc Plated Nylon Insert Lock Nut	
23	1	LW 1/2	LW -1/2" Zinc Plated Medium Split	
24	2	LW 3/8	LW - 3/8" Zinc Plated Medium Split	

Indicator

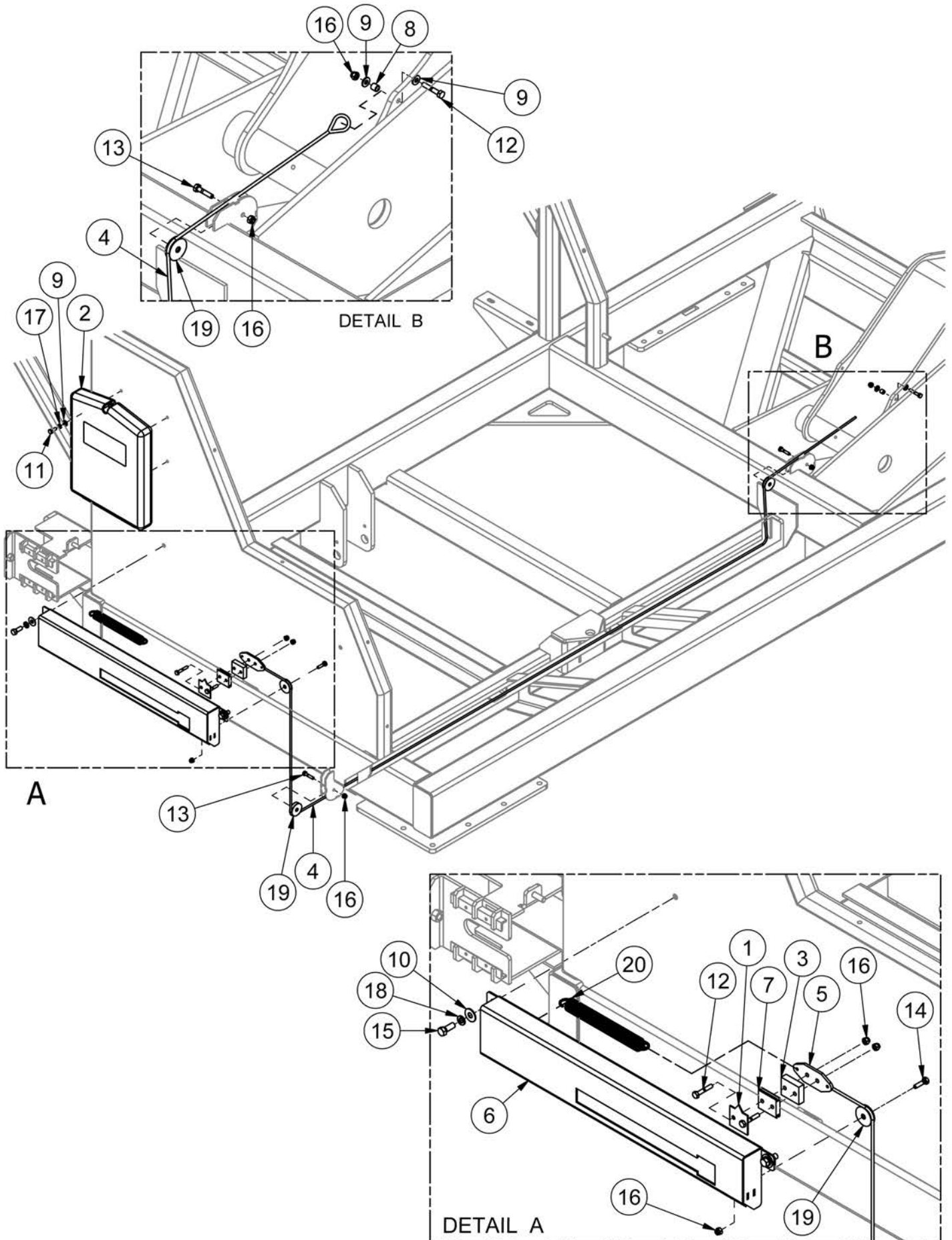

Indicator

ITEM	QTY	PART NUMBER	DESCRIPTION
1	1	45409	Indicator Arrow
2	1	48199	Manual Case Holder
3	1	49612	Indicator Spacer Plate
4	1	49615	Indicator Cable
5	1	49618	Indicator Cable Mount Plate
6	1	49623	Indicator Frame
7	1	BF5000-183	Indicator Slider
8	1	BF5000-269	Cable Spacer
9	7	FW 1/4	Flatwasher - 1/4" Zinc Plated USS
10	2	FW 3/8	Flatwasher - 3/8" Zinc Plated USS
11	4	HB1/4-20X0.75Z5	Hex Bolt 1/4-20x3/4 Grade 5 Zinc Plated Hex Cap Screw
12	3	HB1/4-20X1.5Z5	Hex Bolt 1/4-20x1 1/2 Grade 5 Zinc Plated Hex Cap Screw
13	3	HB1/4-20X1.25Z5	Hex Bolt 1/4-20x1 1/4 Grade 5 Zinc Plated Hex Cap Screw
14	1	HB1/4-20X1Z5	Hex Bolt 1/4-20x1 Grade 5 Zinc Plated Hex Cap Screw
15	2	HB3/8-16X1Z5	Hex Bolt 3/8-16x1 Grade 5 Zinc Plated Hex Cap Screw
16	7	LN1/4-20NCZ5	LN 1/4-20 Zinc Plated Nylon Insert Lock Nut
17	4	LW 1/4	LW - 1/4" Zinc Plated Medium Split
18	2	LW 3/8	LW - 3/8" Zinc Plated Medium Split
19	4	PP00423	Pulley
20	1	PP00491	Spring 8.5 X 1.0 X .105

Bale Bed Cylinder Hydraulics

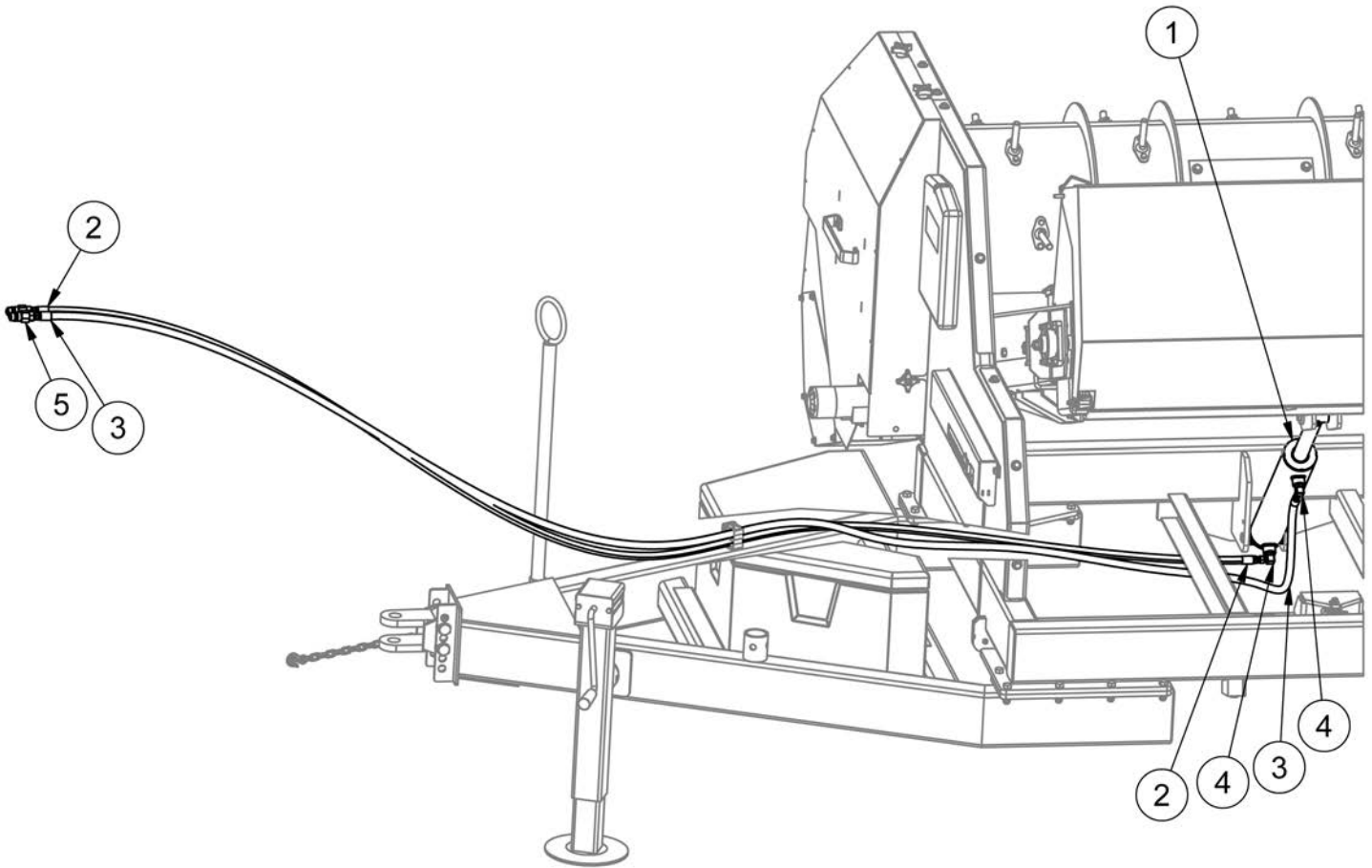

ITEM	QTY	PART NUMBER	DESCRIPTION
1	1	49803	3" Bore x 16" Stroke Hydraulic Cylinder
2	1	48162	Hose - HH145 - 6AT1 (6FJX,8MP) HCL 145"
3	1	48163	Hose - HH159 - 6AT1 (6FJX,8MP) HCL 159"
4	4	HF 6801-6-8	Hyd Fitting - Male JIC - Male ORB 90°
5	4	HF 8010-4	Quickcoupler 1/2" Male Tip

Conveyor Motor Hydraulics

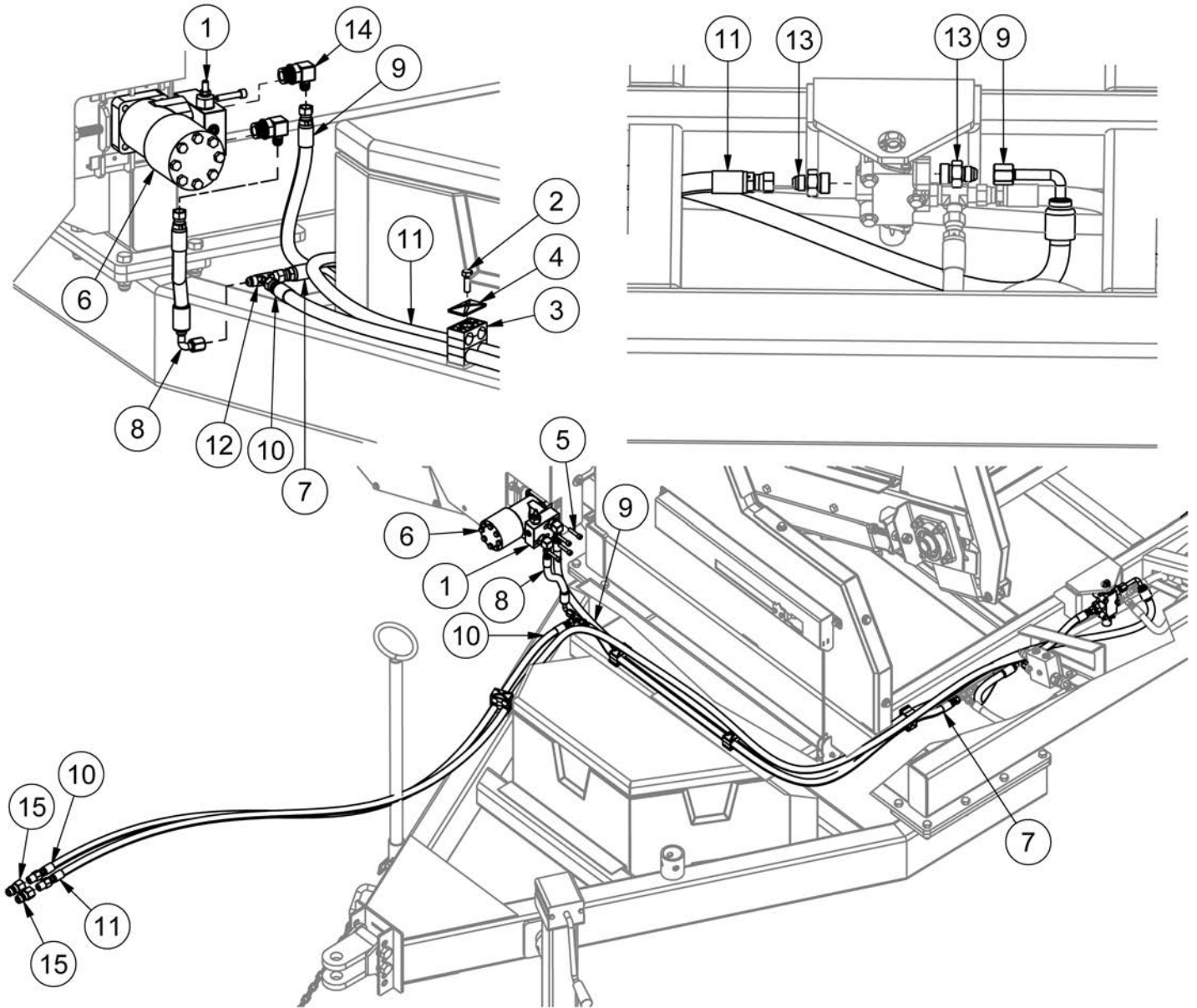

ITEM	QTY	PART NUMBER	DESCRIPTION
1	1	47996	Hydraulic Cross Port Relief for Motor
2	1	HB5/16-18X1Z5	Hex Bolt 5/16-18x1 Grade 5 Zinc Plated Hex Cap Screw
3	12	LA-HOSE CLAMP 2	Plastic 3/8" Hose Clamp
4	5	LA-HOSE CLAMP 3	Top Plate 3/8" Hose Clamp
5	4	SHCS5/16-18X1.5	Hex Bolt - 5/16-18 x 1 1/2 Socket Head Cap Screw
6	1	VAL 1008	Motor, Hydraulic - (BS208107A)
7	1	48149	Hose - HH55 - 6AT1 (6FJX,6FJX) HCL 55"
8	1	48150	Hose - HH7 - 6AT1 (6FJX,6FJX90) HCL 7"
9	1	48151	Hose - HH94 - 6AT1 (6FJX,6FJX90L) HCL 94"
10	1	48153	Hose - HH102 - 6AT1 (6FJX,8MP) HCL 102"
11	1	48154	Hose - HH177 - 6AT1 (6FJX,8MP) HCL 177"
12	2	HF 2603-6-6-6	Male JIC Tee
13	10	HF 6400-6-8	Hyd Fitting -Male JIC - Male ORB
14	2	HF 6801-6-10	Hydraulic Fitting - 90° JIC to O-Ring
15	4	HF 8010-4	Quickcoupler 1/2" Male Tip

Main Hydraulics

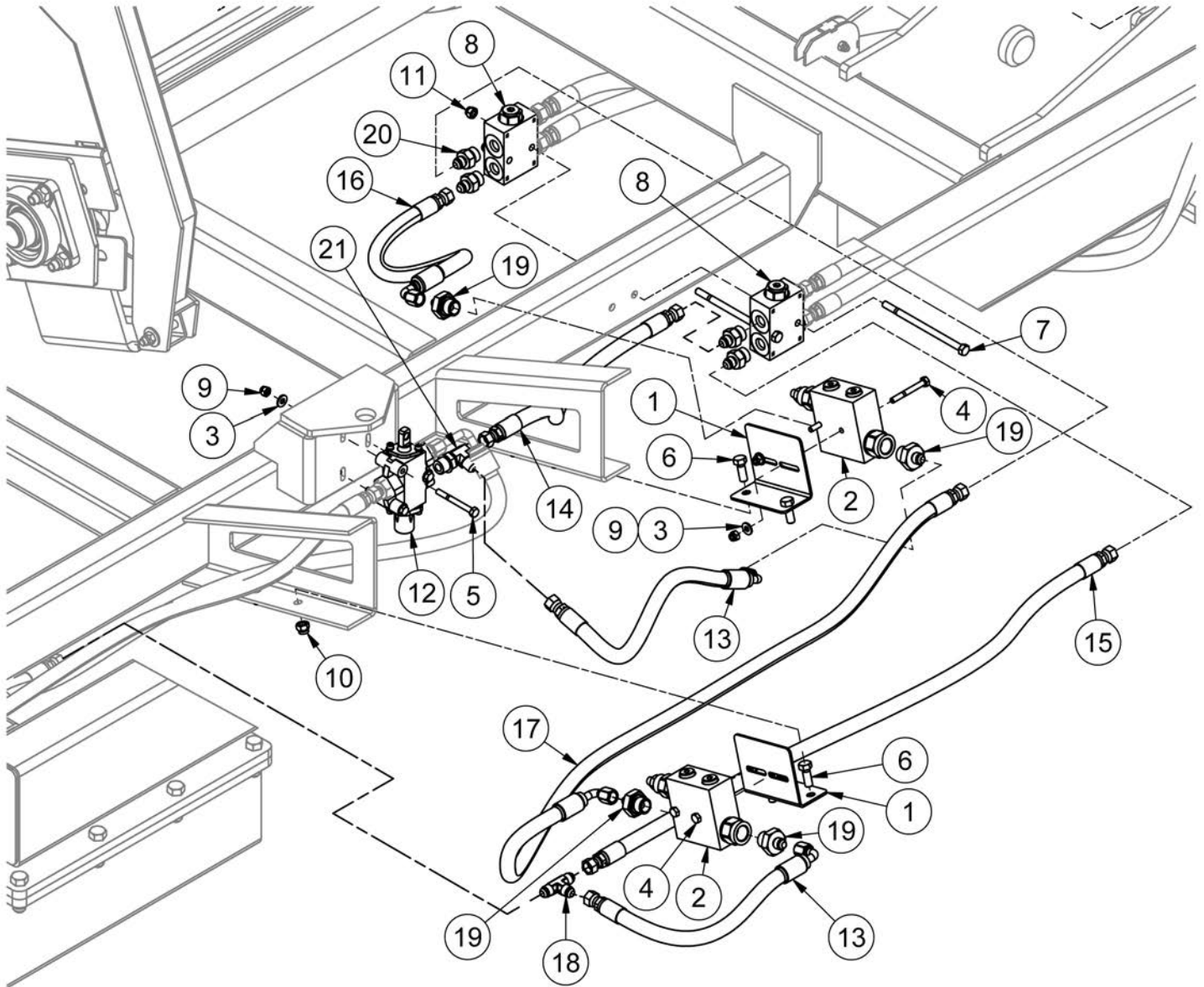

Main Hydraulics

ITEM	QTY	PART NUMBER	DESCRIPTION
1	2	47749	Sequencing Valve Mount
2	2	49917	VSQ80CC1202 2 Port Sequencing Valve
3	20	FW 1/4	Flatwasher - 1/4" Zinc Plated USS
4	4	HB1/4-20X2.25Z5	Hex Bolt 1/4-20x2 1/4 Grade 5 Zinc Plated Hex Cap Screw
5	3	HB1/4-20X2.5Z5	Hex Bolt 1/4-20x2 1/2 Grade 5 Zinc Plated Hex Cap Screw
6	37	HB3/8-16X1Z5	Hex Bolt 3/8-16x1 Grade 5 Zinc Plated Hex Cap Screw
7	2	HB5/16-18X5.5Z5	Hex Bolt 5/16-18x5 1/2 Grade 5 Zinc Plated Hex Cap Screw
8	2	LA-VBSL08S	Pilot Operated Check Valve
9	16	LN1/4-20NCZ5	LN 1/4-20 Zinc Plated Nylon Insert Lock Nut
10	161	LN3/8-16NCZ5	LN 3/8-16 Zinc Plated Nylon Insert Lock Nut
11	2	LN5/16-18NCZ5	LN 5/16-18 Zinc Plated Nylon Insert Lock Nut
12	1	PP00566	Diverter Valve DA5/3A 12MESLB-SAE
13	2	48148	Hose - HH13 - 6AT1 (6FJX,6FJX90) HCL 13"
14	1	50313	Hose - HH15 - 6AT1 (6FJX,6FJX) HCL 15"
15	1	50315	Hose - HH33 - 6AT1 (6FJX,6FJX) HCL 33"
16	1	50319	Hose - HH10 - 6AT1 (6FJX,6FJX90) HCL10"
17	1	51230	Hose - HH39 - 6AT1 (6FJX,6FJX90) HCL 39"
18	2	HF 2603-6-6-6	Male JIC Tee
19	4	HF 3800-06-08	Hyd Fitting - 3/8 JIC to 1/2 BSPP
20	10	HF 6400-6-8	Hyd Fitting -Male JIC - Male ORB
21	1	HF 6804-6-8-6	Hydraulic Fitting - Male JIC - Male ORB Tee



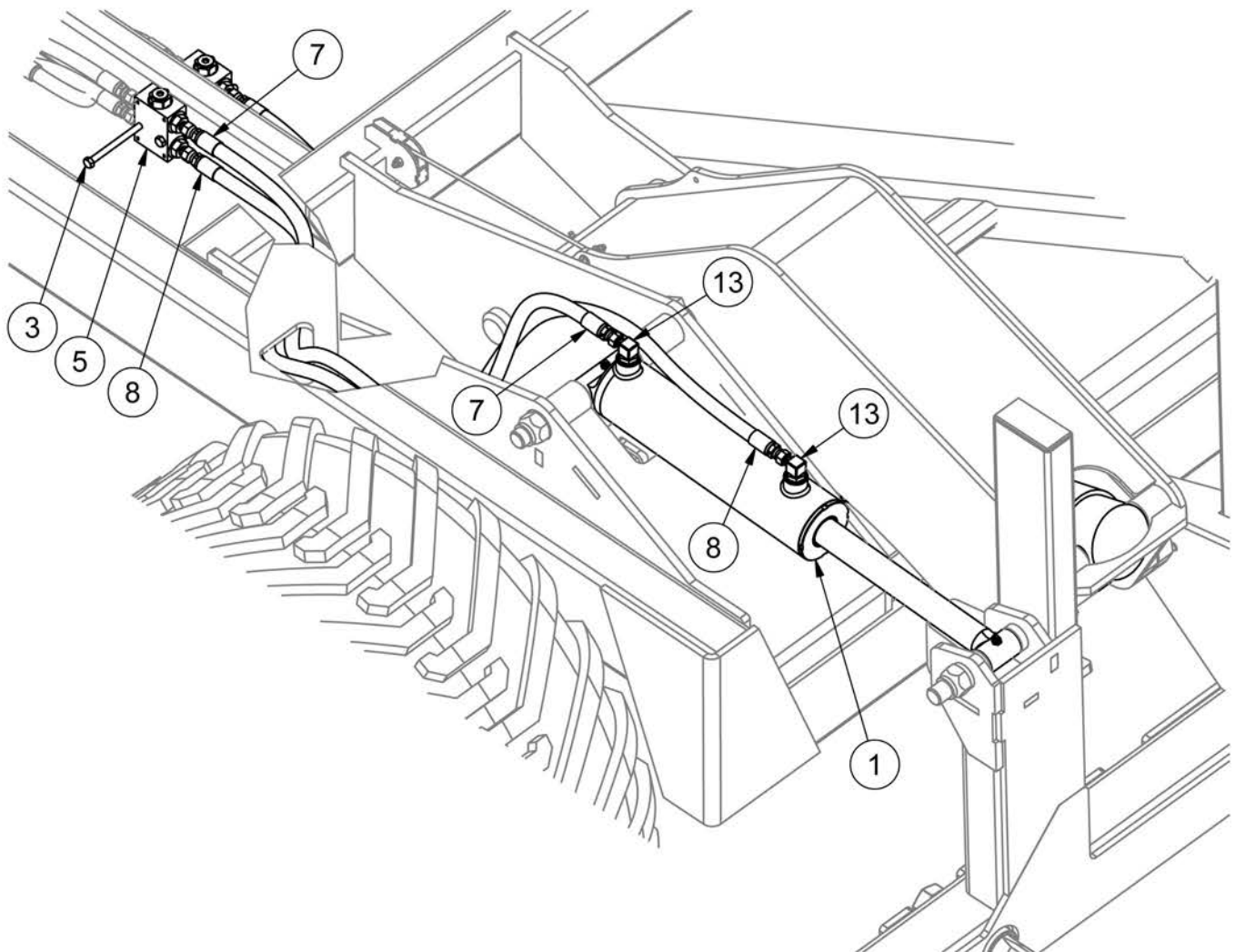
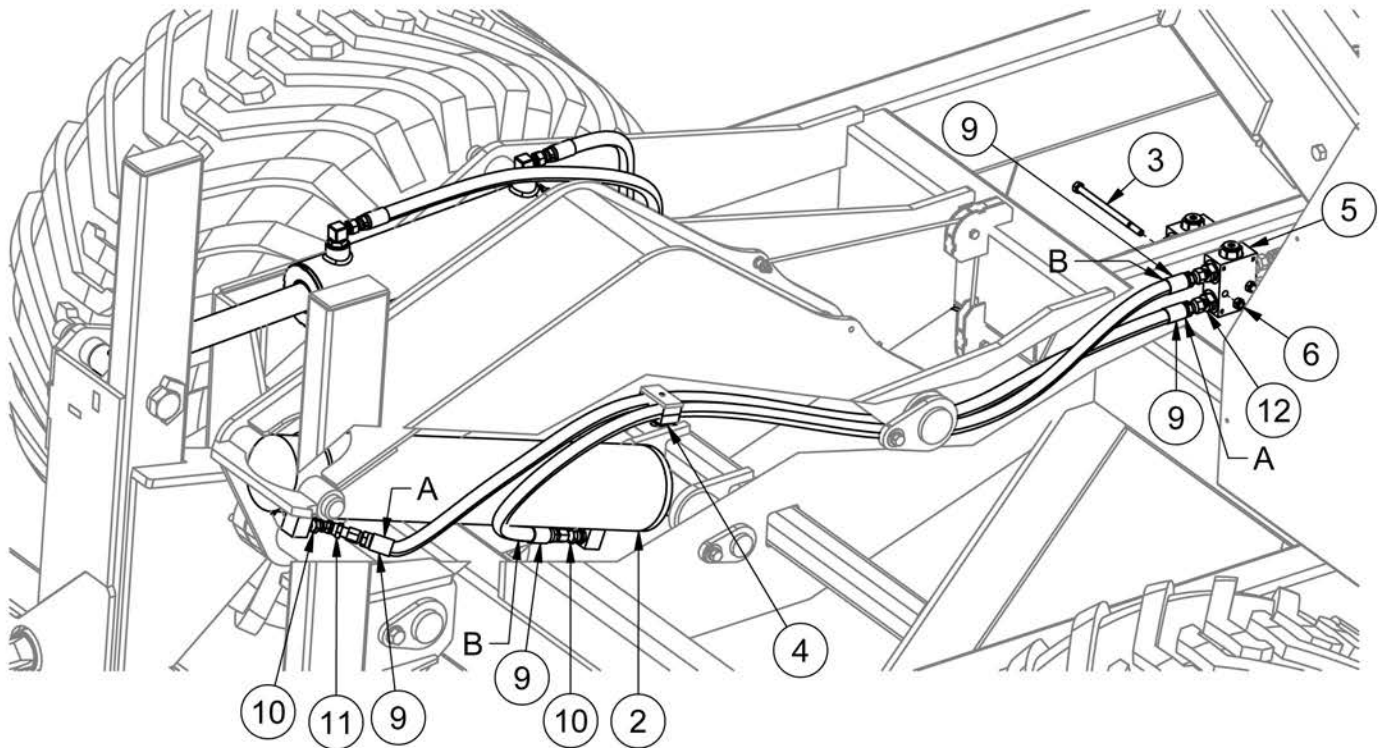







Loading Arm Hydraulics



Loading Arm Hydraulics

ITEM	QTY	PART NUMBER	DESCRIPTION
1	1	49916	3" Bore x 10" Stroke Hydraulic Cylinder
2	1	CYL-4001901	4" Bore x 19" Stroke Hydraulic Cylinder
3	2	HB5/16-18X5.5Z5	Hex Bolt 5/16-18x5 1/2 Grade 5 Zinc Plated Hex Cap Screw
4	1	LA-HOSE CLAMP	Hose Clamp - 3/8"
5	2	LA-VBSL08S	Pilot Operated Check Valve
6	2	LN5/16-18NCZ5	LN 5/16-18 Zinc Plated Nylon Insert Lock Nut
7	1	50314	Hose - HH50 - 6AT1 (6FJX,6FJX) HCL 50"
8	1	50316	Hose - HH62 - 6AT1 (6FJX,6FJX) HCL 62"
9	2	50318	Hose - HH63 - 6AT1 (6FJX,4MP) HCL63"
10	2	HF 1404-4-4	Male NPT X Female NPSM Adapter
11	1	HF 1503-4-4	Hyd. Forged Fitting MPT to FPT 45 Degree
12	10	HF 6400-6-8	Hyd Fitting -Male JIC - Male ORB
13	4	HF 6801-6-8	Hyd Fitting - Male JIC - Male ORB 90°

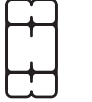
Torque Values - Imperial

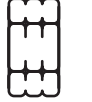
SAE Grade and Head Markings	NO MARK	1 or 2 ^b 	5 	5.1 	5.2 	8 	8.2 
	NO MARK	2 	5 			8 	

Size	Grade 1				Grade 2 ^b				Grade 5, 5.1, or 5.2				Grade 8 or 8.2			
	Lubricated ^a		Dry ^a		Lubricated ^a		Dry ^a		Lubricated ^a		Dry ^a		Lubricated ^a		Dry ^a	
	N-m	lb-ft	N-m	lb-ft	N-m	lb-ft	N-m	lb-ft	N-m	lb-ft	N-m	lb-ft	N-m	lb-ft	N-m	lb-ft
1/4	3.7	2.8	4.7	3.5	6	4.5	7.5	5.5	9.5	7	12	9	13.5	10	17	12.5
5/16	7.7	5.5	10	7	12	9	15	11	20	15	25	18	28	21	35	26
3/8	14	10	17	13	22	16	27	20	35	26	44	33	50	36	63	46
7/16	22	16	28	20	35	26	44	32	55	41	70	52	80	58	100	75
1/2	33	25	42	31	53	39	67	50	85	63	110	80	120	90	150	115
9/16	48	36	60	45	75	56	95	70	125	90	155	115	175	130	225	160
5/8	67	50	85	62	105	78	135	100	170	125	215	160	240	175	300	225
3/4	120	87	150	110	190	140	240	175	300	225	375	280	425	310	550	400
7/8	190	140	240	175	190	140	240	175	490	360	625	450	700	500	875	650
1	290	210	360	270	290	210	360	270	725	540	925	675	1050	750	1300	975
1-1/8	400	300	510	375	400	300	510	375	900	675	1150	850	1450	1075	1850	1350
1-1/4	570	425	725	530	570	425	725	530	1300	950	1650	1200	2050	1500	2600	1950
1-3/8	750	550	950	700	750	550	950	700	1700	1250	2150	1550	2700	2000	3400	2550
1-1/2	1000	725	1250	925	990	725	1250	930	2250	1650	2850	2100	3600	2650	4550	3350

DO NOT use these values if a different torque value or tightening procedure is given for a specific application. Torque values listed are for general use only. Check tightness of fasteners periodically.

Shear bolts are designed to fail under predetermined loads. Always replace shear bolts with identical grade.

Fasteners should be replaced with the same or higher grade. If higher grade fasteners are used, these should only be tightened to the strength of the original.

Make sure fasteners threads are clean and that you properly start thread engagement. This will prevent

them from failing when tightening.

Tighten plastic insert or crimped steel-type lock nuts to approximately 50 percent of the dry torque shown in the chart, applied to the nut, not to the bolt head. Tighten toothed or serrated-type lock nuts to the full torque value.

^a "Lubricated" means coated with a lubricant such as engine oil, or fasteners with phosphate and oil coatings. "Dry" means plain or zinc plated without any lubrication.

^b Grade 2 applies for hex cap screws (not hex bolts) up to 152 mm (6-in.) long. Grade 1 applies for hex cap screws over 152 mm (6-in.) long, and for all other types of bolts and screws of any length.

Torque Values - Metric

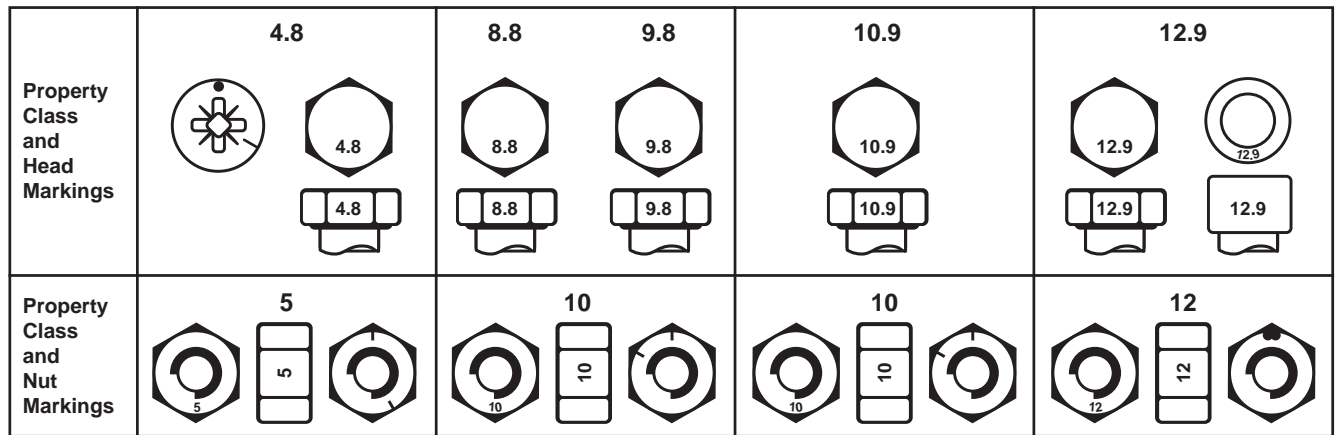

Size	Class 4.8				Class 8.8 or 9.8				Class 10.9				Class 12.9			
	Lubricated ^a		Dry ^a		Lubricated ^a		Dry ^a		Lubricated ^a		Dry ^a		Lubricated ^a		Dry ^a	
	N-m	lb-ft	N-m	lb-ft	N-m	lb-ft	N-m	lb-ft	N-m	lb-ft	N-m	lb-ft	N-m	lb-ft	N-m	lb-ft
M6	4.8	3.5	6	4.5	9	6.5	11	8.5	13	9.5	17	12	15	11.5	19	14.5
M8	12	8.5	15	11	22	16	28	20	32	24	40	30	37	28	47	35
M10	23	17	29	21	43	32	55	40	63	47	80	60	75	55	95	70
M12	40	29	50	37	75	55	95	70	110	80	140	105	130	95	165	120
M14	63	47	80	60	120	88	150	110	175	130	225	165	205	150	260	190
M16	100	73	125	92	190	140	240	175	275	200	350	255	320	240	400	300
M18	135	100	175	125	260	195	330	250	375	275	475	350	440	325	560	410
M20	190	140	240	180	375	275	475	350	530	400	675	500	625	460	800	580
M22	260	190	330	250	510	375	650	475	725	540	925	675	850	625	1075	800
M24	330	250	425	310	650	475	825	600	925	675	1150	850	1075	800	1350	1000
M27	490	360	625	450	950	700	1200	875	1350	1000	1700	1250	1600	1150	2000	1500
M30	675	490	850	625	1300	950	1650	1200	1850	1350	2300	1700	2150	1600	2700	2000
M33	900	675	1150	850	1750	1300	2200	1650	2500	1850	3150	2350	2900	2150	3700	2750
M36	1150	850	1450	1075	2250	1650	2850	2100	3200	2350	4050	3000	3750	2750	4750	3500

DO NOT use these values if a different torque value or tightening procedure is given for a specific application. Torque values listed are for general use only. Check tightness of fasteners periodically.

Shear bolts are designed to fail under predetermined loads. Always replace shear bolts with identical property class.

Fasteners should be replaced with the same or higher property class. If higher property class fasteners are used, these should only be tightened to the strength of the original.

Make sure fasteners threads are clean and that you

properly start thread engagement. This will prevent them from failing when tightening.

Tighten plastic insert or crimped steel-type lock nuts to approximately 50 percent of the dry torque shown in the chart, applied to the nut, not to the bolt head. Tighten toothed or serrated-type lock nuts to the full torque value.

^a "Lubricated" means coated with a lubricant such as engine oil, or fasteners with phosphate and oil coatings. "Dry" means plain or zinc plated without any lubrication.

Index

45179 - Finger Drum Update Kit	7-12
Bale Bed7-6
Bale Bed Conveyor7-8
Bale Bed Cylinder Hydraulics	7-28
Bale Indicator4-1
Bales1-1
Bale Spear Installation3-1
Bed Stop5-2
Bed Stop Diverter Valve4-3
Conveyor Chain Tightening4-2
Conveyor Motor Hydraulics	7-29
Daily Maintenance6-3
Decal Locations2-3
Dimensions1-1
Drum - Current	7-14
Drum - Original Welded End	7-10
End of Season Service6-3
Frame7-2
Front Chain Drive - Current	7-18
Front Chain Drive - Original	7-16
Grease Point Locations6-2
Grease Points6-1
Hitch Height4-1
Hydraulic Safety2-2
Indicator	7-26
Initial Setup3-1
Inner Shielding7-4
Loading Arm	7-24
Loading Arm Hydraulics	7-32
Loading Arm Valve4-2
Loading Bales5-1
Main Hydraulics	7-30
Maintenance Safety2-2
Manuals I
Model Decals2-7
Motor Drive Chain Tightening4-2
Operator's Manual I
Orientation1-2
Personal Protective Equipment2-2
Power Unit Hookup3-1
Power Unit Requirements1-1
Preseason Service6-3
Rear Apron Chain - Current	7-22
Rear Apron Chain - Original	7-20

Safety Decals2-5
Safety Decals, continued2-6
Safety Guidelines.2-1
Safety Signal Words / Safety Messages.2-1
Section 1: General Information1-1
Section 2: Safety2-1
Section 3: Pre-Operation3-1
Section 4: Adjustments4-1
Section 5: Operation5-1
Section 6: Maintenance6-1
Section 8: Parts Breakdowns & Lists.7-1
Serial Number. I
Terminology1-2
Tire Load Index Chart1-2
Torque Values - Imperial8-1
Torque Values - Metric9-1
Unloading5-3
Usage1-1
Warranty and Limitation of Liability I



Scan with smartphone to
download latest manual.

TUBE•LINE™